

Technical data

Fuse-link D

Technical data	
Rated voltage U_n	500 V AC, 600 V AC, 750 V AC, 1200 V AC, 400 V DC
Rated current I_n	DI, DII 2 - 25 A, DIII 32 - 63 A DIV 80 - 100 A, DV 125 - 200 A
Breaking capacity at 1,1 U_n	50 kA AC $\cos\phi = 0,2$ 8 kA DC $T = 15 \text{ ms}$
Fusing characteristics	gG, TDZ, DZ
Insulating class	C - VDE 0110
Standards	DIN EN 60269-1, IEC 60269-1:2005-04 (VDE 0636 Teil 10): 1999-11 DIN EN 60269-3, IEC 60269-3:2003 (VDE 0636 Teil 30): 1995-12 DIN EN 60269-3-1, IEC 60269-3-1: 2004-07 (VDE 0636 Teil 301): 1998-01 DIN VDE 0635/02.84

DI for fuse base E 16

I_n [A]	dimension	
	$\varnothing A$	$\varnothing B$
2	13,2	6
4	13,2	6
6	13,2	6
10	13,2	8
16	13,2	10
20	13,2	12
25	13,2	14

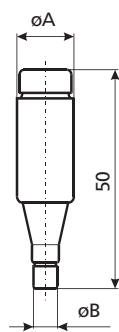

DII for fuse base E 27

I_n [A]	dimension	
	$\varnothing A$	$\varnothing B$
2	21,5	6
4	21,5	6
6	21,5	6
10	21,5	8
13	21,5	8
16	21,5	10
20	21,5	12
25	21,5	14

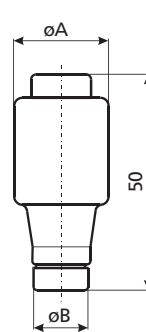

DIII for fuse base E 33

I_n [A]	dimension	
	$\varnothing A$	$\varnothing B$
32	27	16
35	27	16
40	27	16
50	27	18
63	27	20

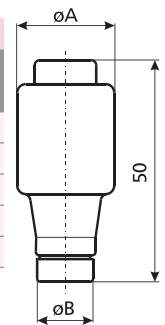

DIV for fuse base R1 1/4"

I_n [A]	dimension	
	$\varnothing A$	$\varnothing B$
80	33	5
100	33	7

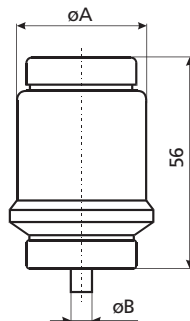

DIII gG, 690 V a.c., 600 V d.c.

I_n [A]	dimension	
	$\varnothing A$	$\varnothing B$
2	27	6
4	27	6
6	27	6
10	27	8
16	27	10
20	27	12
25	27	14
35	27	16
50	27	18
63	27	20

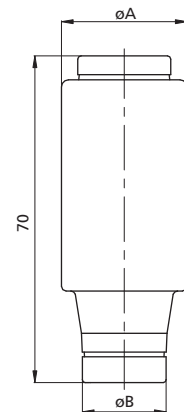

DV for fuse base R 2"

I_n [A]	dimension	
	$\varnothing A$	$\varnothing B$
125	46	5
160	46	7
200	46	9

DIII gF, 750V a.c.

I_n [A]	dimension	
	$\varnothing A$	$\varnothing B$
2	27	6
4	27	6
6	27	6
10	27	8
16	27	10
20	27	12
25	27	14
35	27	16

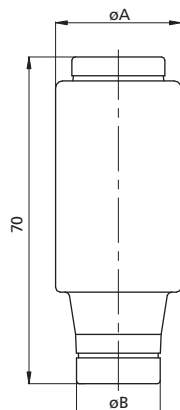

DIII gF, 1200 V a.c.

I_n [A]	dimension	
	$\varnothing A$	$\varnothing B$
2	27	6
4	27	6
6	27	6
10	27	8
16	27	10
20	27	12
25	27	14
35	27	16

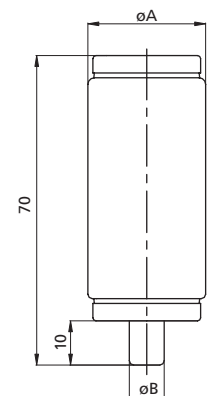

Time current characteristics I/t, gG

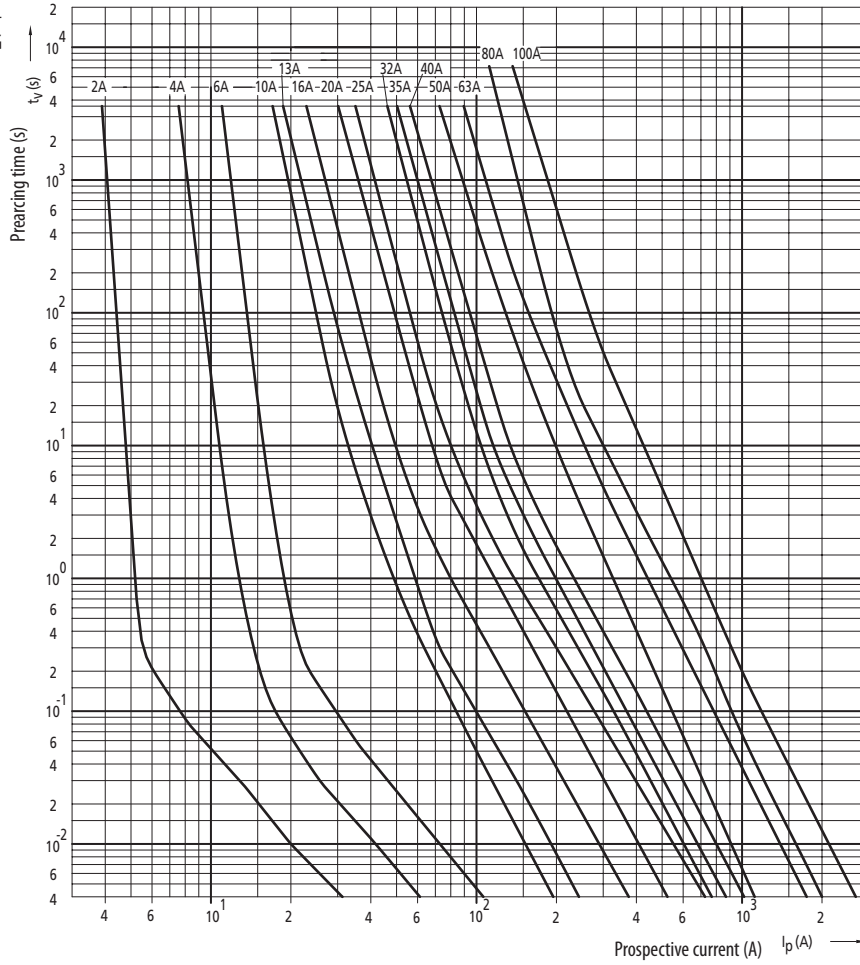

Cut-off current characteristics

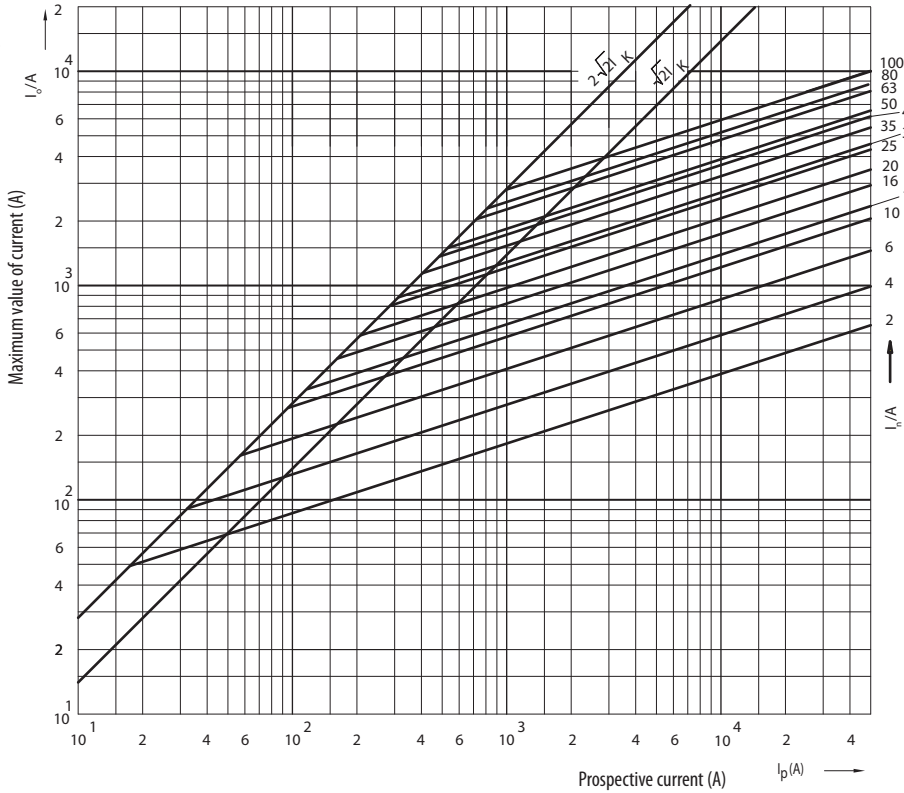

Technical data

Melting energy characteristics I^2t

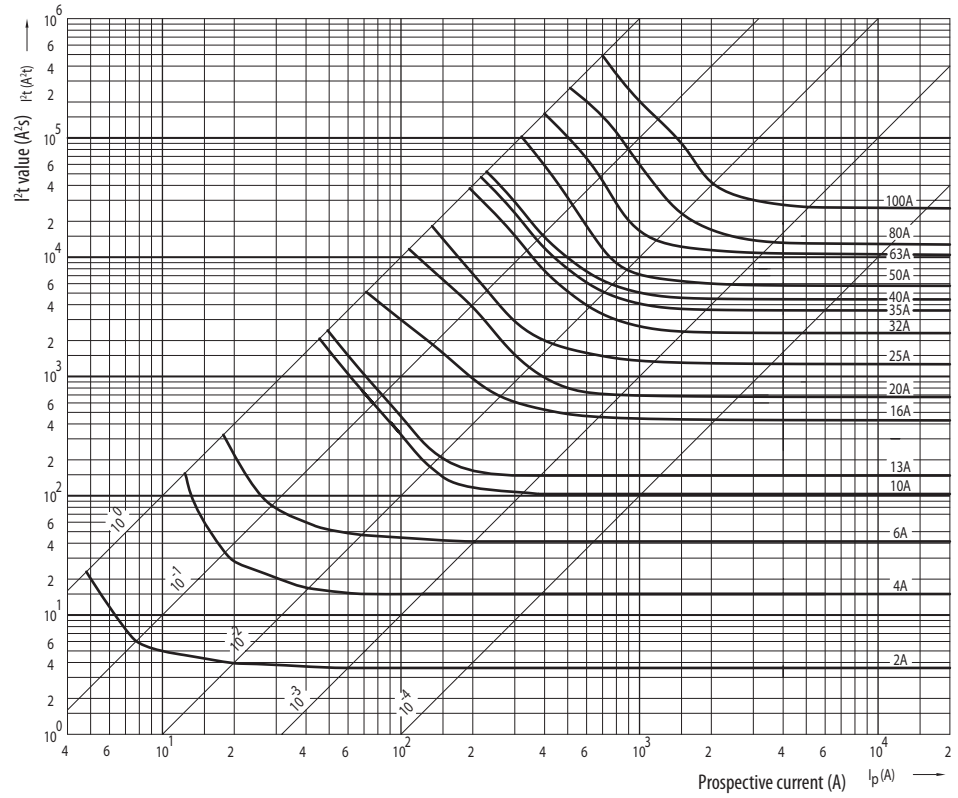

Time current characteristics I/t DZ

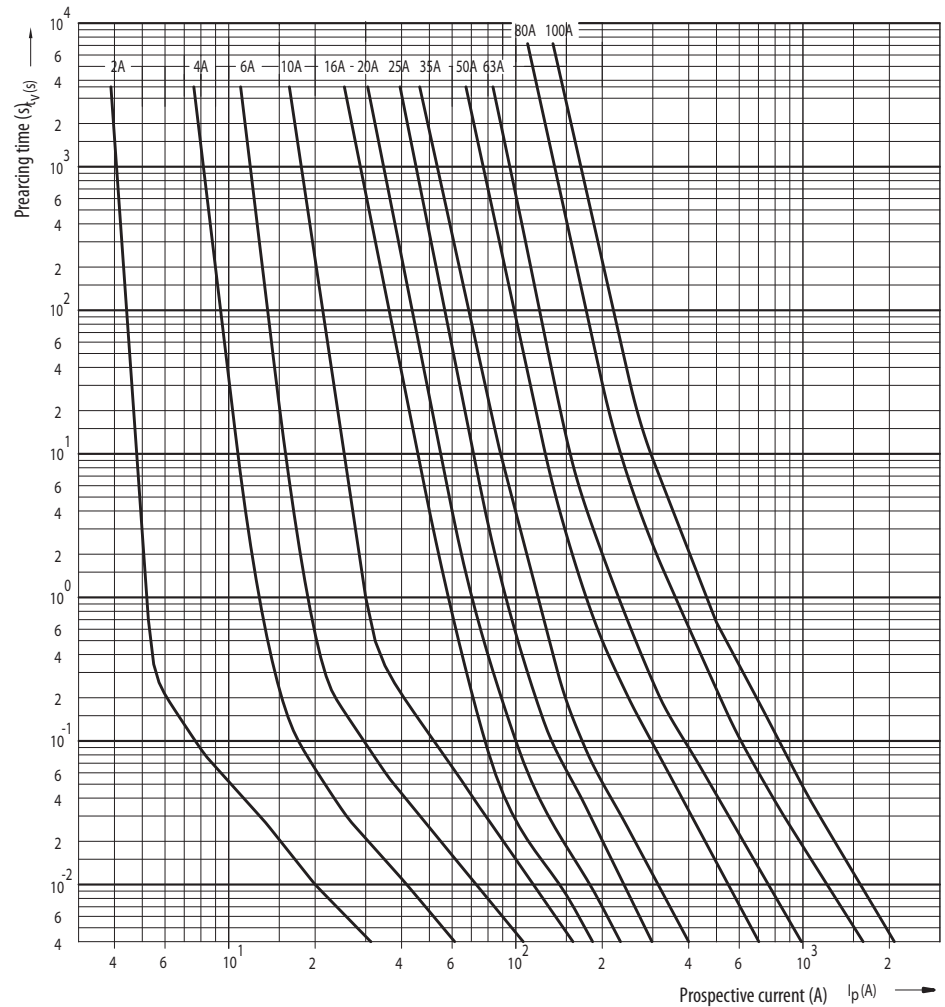

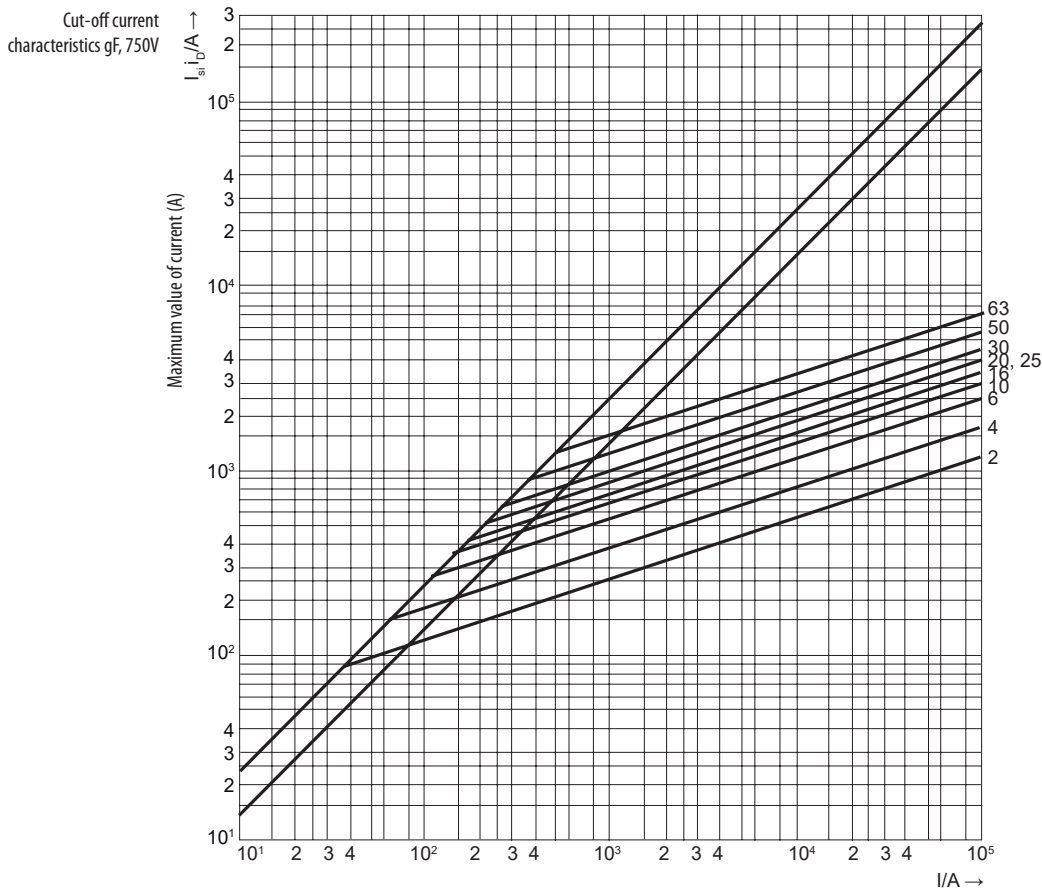
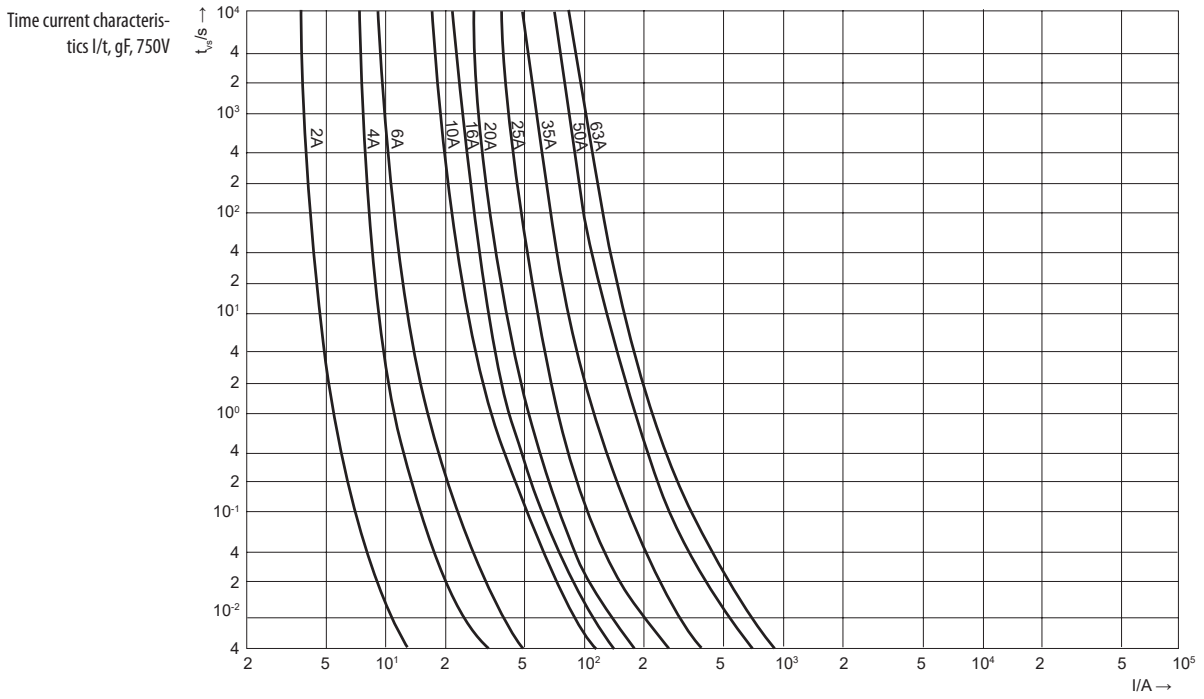

Technical data

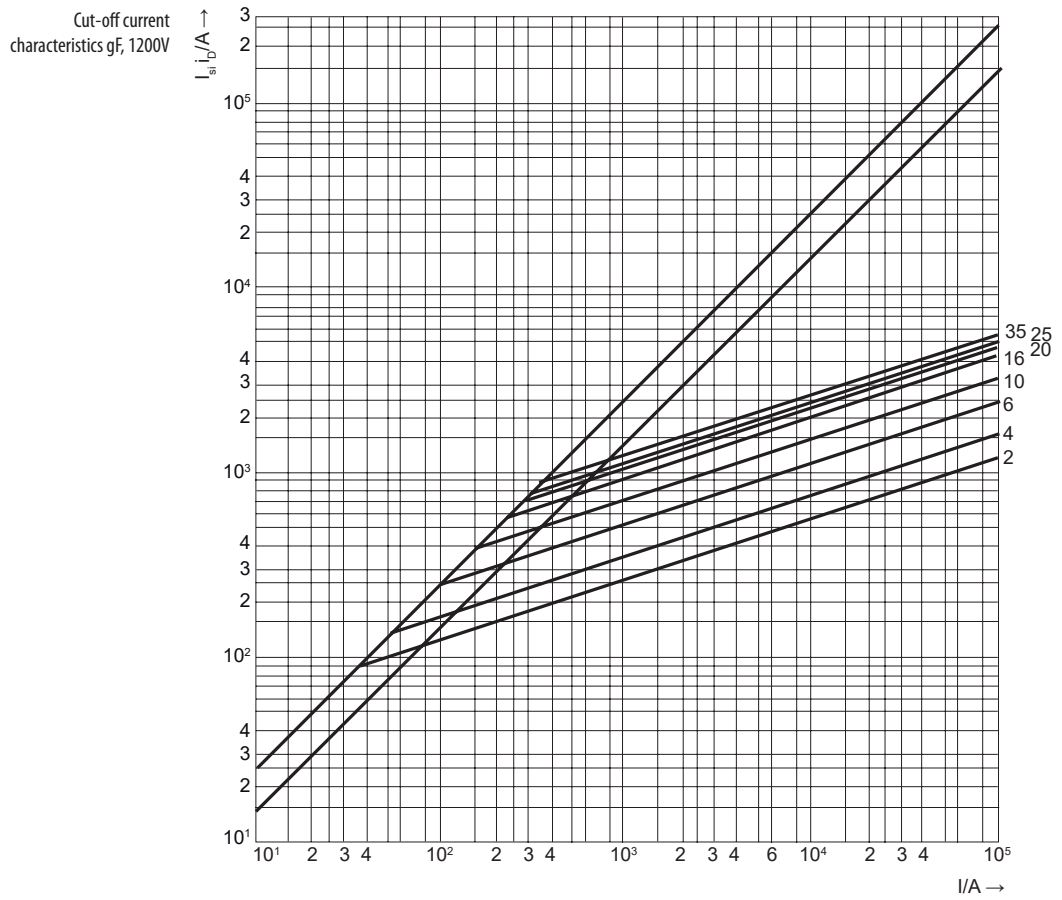
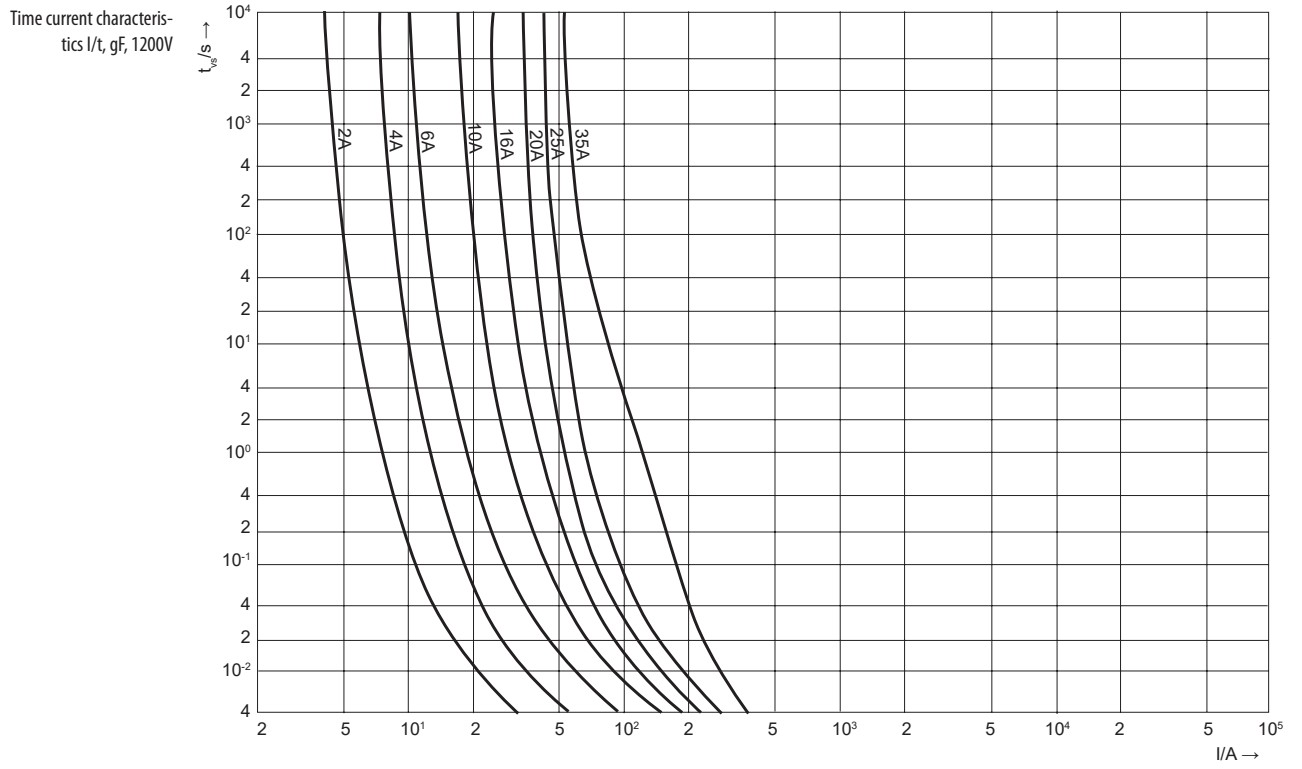

1-pole fuse base

Technical data:

Rated voltage U_n	500 V, 690 V
Rated current I_n	DII 25 A, DIII 63 A
Insulating class	according to IEC 60664-1
Cross-section of connecting lead	DII 1 to 10 mm ² DIII 2,5 to 25 mm ²
Standards, publications	IEC 60269, EN 60269, DIN VDE 0636

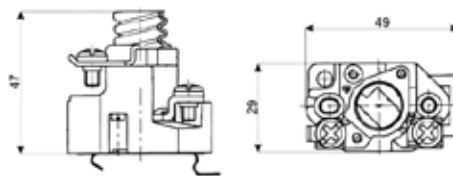

Fuse base DI

Fuse base EZ

type	I_n [A]	dimension						
		A	B	C	D	E	F	G
EZ	25	41	47	36	20	35	13	46
EZ	63	45	56	45	20	36	14	58

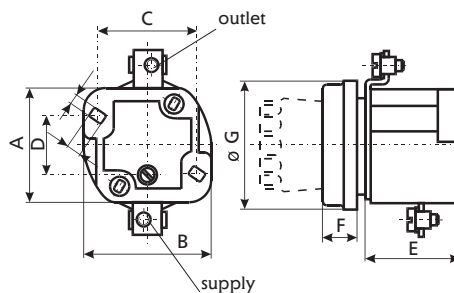

Fuse base TZ

type	I_n [A]	dimension						
		A	B	C	D	E	F	G
TZ	25	26	50	53	13,5	14	M	46
TZ	63	31	58	64	16	18	M	58

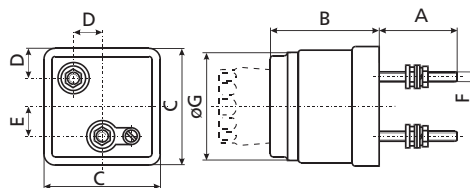

Fuse base UZ, UZN

type	I_n [A]	dimension							
		A	B	C	D	E	F	H	I
UZ	25	56	80	41	33	82	20	4,5	4,5
UZN	25	56	80	41	33	82	20	4,5	4,5
UZ	63	56	90	52	41	82	28	4,5	4,5
UZN	63	56	90	52	41	82	28	4,5	4,5

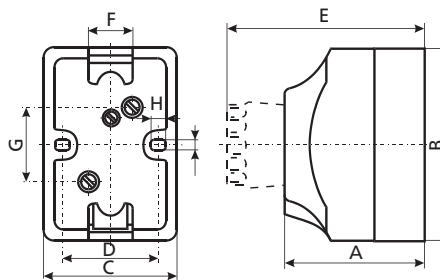

Fuse base EZR

type	I_n [A]	dimension			
		A	B	C	D
EZR	25	42	46	45	35
EZR	63	47	58	48,5	38

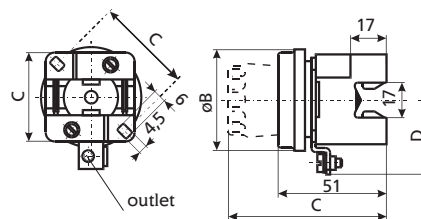

Technical data

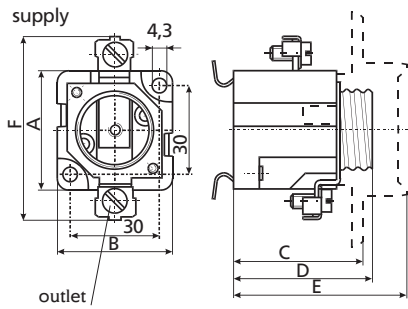

Fuse base EZN, EZV

type	I _n [A]	dimension					
		A	B	C	D	E	F
EZN 25°	25	41	39	44	47	60	62
EZN 63°	63	43	47	44	47	56	79
EZN 63-M6°	63	43	47	44	47	56	79
EZV 25	25	41	39	44	47	60	62
EZV 63	63	43	47	44	47	56	79
EZV 63-M6	63	43	47	44	47	56	79
EZN 25-ZP*	25	41	39	44	47	60	62
EZN 63-ZP*	63	43	47	44	47	56	79
EZV 25-ZP*	25	41	39	44	47	60	62
EZV 63-ZP*	63	43	47	44	47	56	79

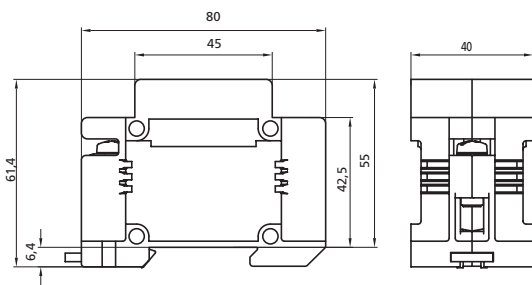

Fuse base D Comfort

Rated voltage U _n	500 V
Rated current I _n	25 A
For fuse-links type DII	acc. to IEC/EN 60269-3
Gauge pieces VDII	acc. to IEC/EN 60269-3
Cross section of connecting leads	1,5 - 25 mm ²
Screws	with ±head
Mounting possibilities:	- with screws - mounting on the rail EN 60715

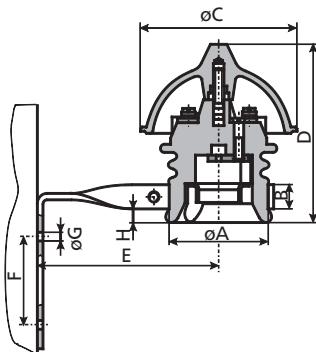

Fuse base for overhead lines

type	I _n [A]	dimension							
		øA	B	øC	D	E	F	øG	H
FZ	25	61	14	104	118	90	50	7	20
FZ	65	70	21	114	120	130	58	7	21

3-pole fuse base

Fuse base EZN/3, EZV/3 - LINEAR

type	dimension							
	A	B	C	D	E	F	øG	H
EZN 25/3	41	121	44	47	60	30	4,3	50
EZN 25/3	41	121	44	47	60	30	4,3	50
EZN 63/3	43	148	44	47	56	32	4,3	62
EZN 63/3	43	148	44	47	56	32	4,3	62

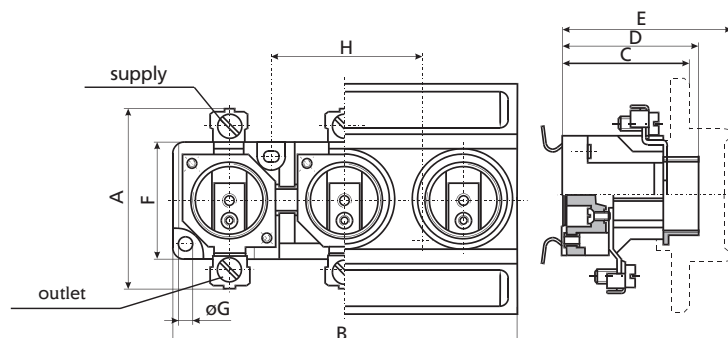

Fuse base EZN/3, EZV/3 - DELTA

type	dimension							
	A	B	C	D	E	F	G	H
EZN 25/3	106	106	48	/	/	45	52	86
EZV 25/3	106	106	48	32	5,2	45	52	86
EZN 63/3	127	130	54	/	/	45	52	85
EZV 63/3	127	130	54	32	5,2	45	52	85

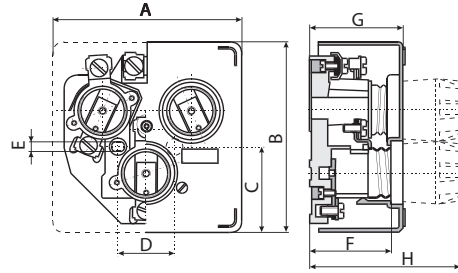

Armoured fuse base

type	dimension								
	A	B	C	D	E	F	G	H	I
T 25/3N	106	106	48	/	/	45	52	86	97
T 63/3N	127	130	54	/	/	45	52	85	97
T 25/3V	106	106	48	32	5,2	45	52	86	97
T 63/3V	127	130	54	32	5,2	45	52	85	97

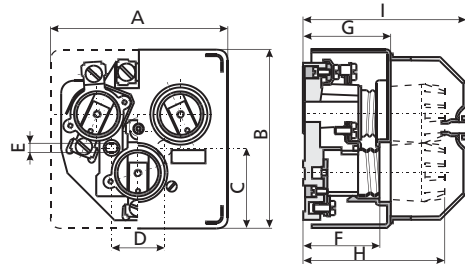

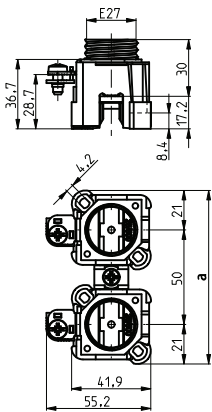

D fuse base - new generation

SET EZR 25 2p - 10p



SET EZR 25 2p

Fuse base EZR 25

type	connection		Cross-section of connecting lead		Dimension a
	Supply	Outlet	Outlet [mm ²]	Supply [mm ²]	
SET EZR 25 2p-GEG 25.2			35	1 - 10	92
SET EZR 25 3p-GEG 25.3				1 - 10	142
SET EZR 25 4p-GEG 25.4				1 - 10	192
SET EZR 25 5p-GEG 25.5				1 - 10	242
SET EZR 25 6p-GEG 25.6				1 - 10	292
SET EZR 25 7p-GEG 25.7				1 - 10	342
SET EZR 25 8p-GEG 25.8				1 - 10	392
SET EZR 25 9p-GEG 25.9				1 - 10	442
SET EZR 25 10p-GEG 25.10				1 - 10	491

SET EZR 63 2p - 6p

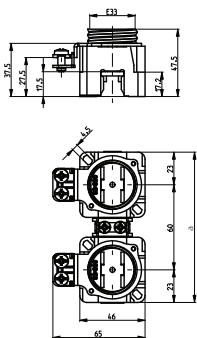

SET EZR 63 2p

Fuse base EZR 63

type	Connection	Cross-section of connecting lead		Dimension a
		Outlet [mm ²]	Supply [mm ²]	
SET EZR 63 2p-GEG 63.2		35	2.5 - 25	106
SET EZR 63 3p-GEG 63.3			2.5 - 25	166
SET EZR 63 4p-GEG 63.4			2.5 - 25	226
SET EZR 63 5p-GEG 63.5			2.5 - 25	286
SET EZR 63 6p-GEG 63.6			2.5 - 25	346

Technical data

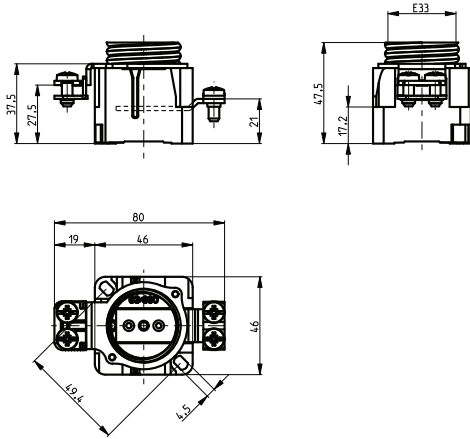

Fuse base EZV 63 GS

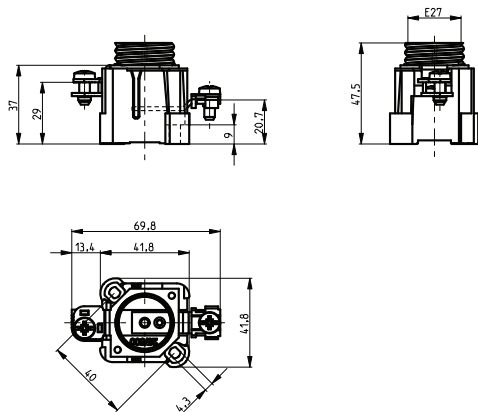

Fuse base EZV 25 GS



Fuse base EZV

type	Connection Supply and Outlet	Cross-section of connecting lead	
		Outlet [mm ²]	Supply [mm ²]
EZV 25 GS	 M5	1 - 10	1 - 10
EZV 63 GS	 2x M5	2.5 - 25	2.5 - 25

Protective cover GB 25.1

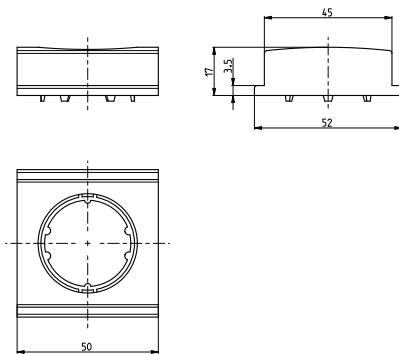

Protective cover GB 25.3

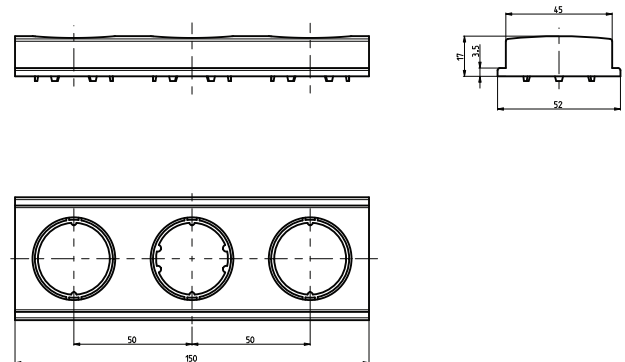

Protective cover GB 63-52

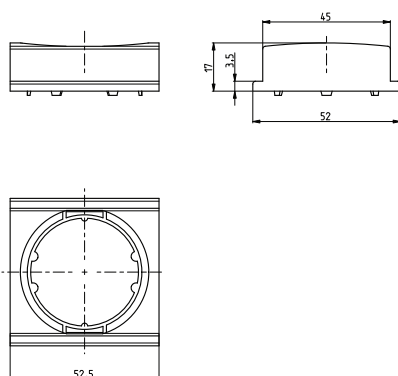

Protective cover GB 63-60

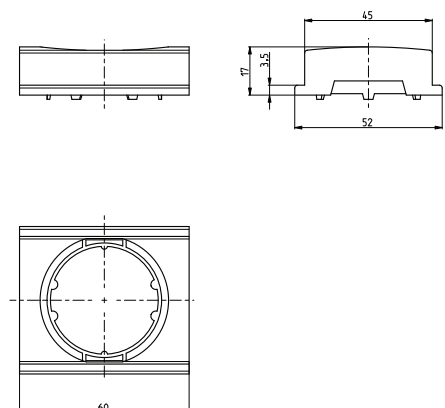

Plastic mounting plate GSA 25

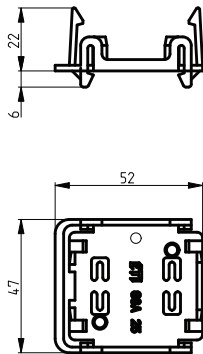

Plastic mounting plate GSA 63

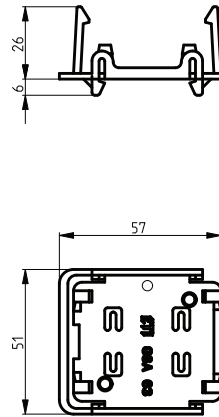

Gauge Piece

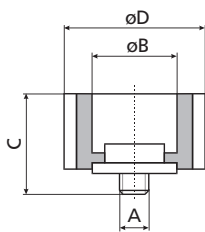

VD II for fuse base E 27

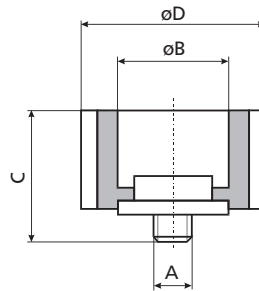

VD III for fuse base E 33

VD II for fuse base E 27

I _n [A]	dimension			
	A	B	C	D
2	3/16"	6,5	17	24
4	3/16"	6,5	17	24
6	3/16"	6,5	17	24
10	3/16"	8,5	17	24
16	3/16"	10,5	17	24
20	3/16"	12,5	17	24
25	3/16"	14,5	17	24

VD III for fuse base E 33

I _n [A]	dimension			
	A	B	C	D
35	3/16"	16,5	17	30
50	3/16"	18,5	17	30
63	3/16"	20,5	17	30

Fuse carrier D

Fuse carrier

type	dimension			
	A	B	C	D
KDI	23	35	10	26
KDII	34	44	12	35
KDIII	43	44	12	43

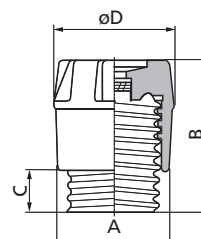

Protection cover

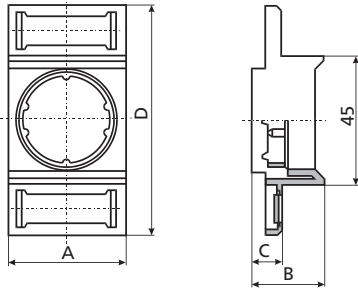

1-pole protection for fuse base

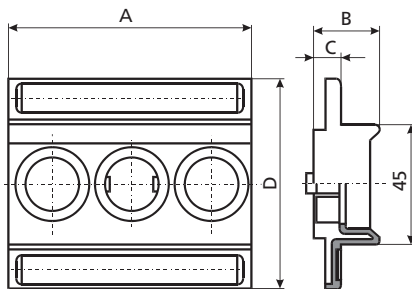
type	I_n [A]	dimension			
		A	B	C	D
EZN, EZV	25	40	24	10,8	80
EZN, EZV	63	49	21	9	80

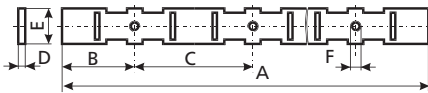

3-pole protection cover for fuse base

type	dimension			
	A	B	C	D
EZN, EZV 25/3	121	24	10,8	80
EZN, EZV 63/3	148	21	9	80

Busbar system for 1-pole fuse base EZR

Busbar for fuse base EZR

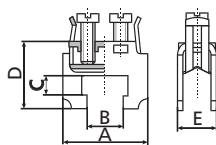
type	I_n [A]	dimension					
		A	B	C	D	E	F
EZR	25	1000	32	52	3	16	3/16"
EZR	63	1000	38	62	3	16	3/16"

Terminals for neutral terminals and busbars EZR

for cross section [mm ²]	dimension				
	A	B	C	D	E
16	25	12,5	3,5	17	7,3
35	28	12,5	6,5	21,5	12,6

