

Battery Fuse

Applications:

- ✓ in battery storage systems
- ✓ in UPS systems
- ✓ in e-mobility

BATTERY FUSE

NEW!



ETI Elektroelement d.d.

Obrezija 5, SI - 1411 Izlake
Slovenija

Tel. + 386 03 56 57 570

Faks + 386 03 56 74 077

eti@eti.si

Battery Protection Fuses

Battery storage fuse selection

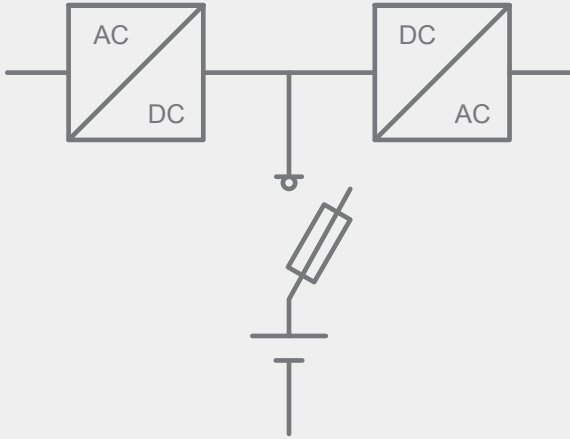

Short circuit current

- Short circuit current depending on battery model, type and capacity, low compared to operating current
- Short circuit current has to be interrupted in <5 seconds

Required steep characteristics: protection with Battery fuse link required!

Operating current

- Operating current depends on battery storage specification
- Battery operation: voltage of DC link circuit decreases to the final discharge voltage

Consider maximum current at final discharge voltage for fuse link selection

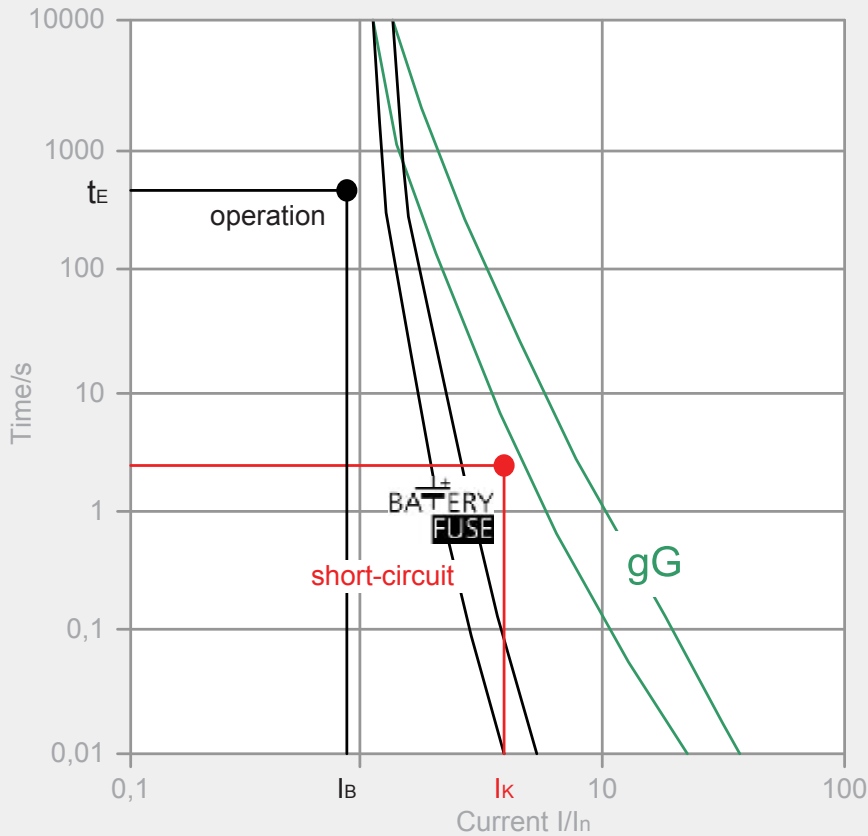

Short circuit point (I_k)

- Short circuit current depending on battery model and type
- Manufacturer datasheets to include short circuit current according to IEC896
- Operating point has to be in adequate distance below the curve
- Short-circuit point has to be above the range of tolerance of the curve

Operating point (t_E/I_B)

- maximum operating current I_B has to be calculated from battery storage true power and final discharge voltage U_E : $I_B = P_w / U_E$
- t_E is the back-up time of battery storage system

When choosing fuse switch disconnector consider fuse link power dissipation!

$$P_d(I_B) < P_y$$

Power dissipation of fuse link at maximal operating current (I_B):

$$P_d(I_B) = (I_B / I_n)^2 \times P_d(I_n)$$

I_B - maximal operating current

$P_d(I_B)$ - power dissipation of fuse link at maximal operating current

$P_d(I_n)$ - power dissipation of fuse link at nominal current

P_y - maximal permissible fuse link power dissipation mounted in fuse switch disconnector

Applications

Telecom



UPS

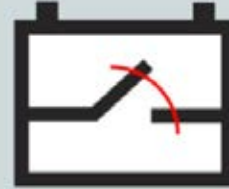

**Emergency
lighting**



Security

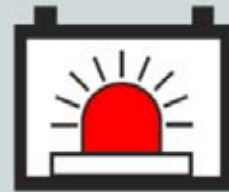

Utility



Railways



Photovoltaic

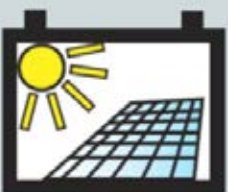

Universal



CH 10x38 BATTERY Fuse link 550V d.c.

General characteristics	
Rated voltage	550V d.c. (L/R=10ms)
Breaking capacity	30kA d.c.
Standard	IEC 60269
Application	Battery protection

CH BATTERY fuse link									
Size	I_n [A]	Code No. "standard contacts" 550V DC 30kA	Code No. "type SU contacts" 550V DC 30kA	Pre-arcing Joule integral L/R=10ms [A ² s]	Operating Joule integral L/R=10ms [A ² s]	Power dissipation [0,7 x I_n] P_d [W]	Power dissipation [1x I_n] P_d [W]	Weight [g]	Pack. [pcs]
10x38	2	002626002	002626102	1,1	1,8	0,47	1,12	10/12	10/500 SU: 10/380
	4	002626004	002626104	3,0	7,8	0,52	1,25		
	6	002626006	002626106	14,1	27,3	0,73	1,75		
	8	002626008	002626108	25,1	53,4	0,8	1,9		
	10	002626010	002626110	8,0	18,8	0,97	2,4		
	12	002626012	002626112	18,5	41,5	0,8	1,9		
	16	002626016	002626116	42	88	1,1	2,6		
	20	002626020	002626120	86	166	1,3	3,2		
	25	002626025	002626125	140	270	1,65	4,1		



Note:
CH Battery fuse links are used in combination
with fuse disconnecter EFH 10 DC

CH 10x38 BATTERY Fuse link 800V d.c.

General characteristics	
Rated voltage	800V d.c. (L/R=10ms)
Breaking capacity	30kA d.c.
Standard	IEC 60269
Application	Battery protection

CH BATTERY fuse link									
Size	I_n	Code No. "standard contacts" 800V DC	Code No. "type SU contacts" 800V DC	Pre-arcing Joule integral L/R=10ms	Operating Joule integral L/R=10ms	Power dissipation [0,7 x I_n] P_d	Power dissipation [1x I_n] P_d	Weight	Pack.
	[A]	30kA	30kA	[A ² s]	[A ² s]	[W]	[W]	[g]	[pcs]
10x38	2	002626030	002626130	1,2	1,6	0,47	1,12	10/12	10/500 SU: 10/380
	4	002626032	002626132	3,6	8,9	0,52	1,25		
	6	002626034	002626134	9,5	27,2	0,73	1,75		
	8	002626036	002626136	27,3	65,8	0,8	1,9		
	10	002626038	002626138	8,2	26,6	0,97	2,4		
	12	002626040	002626140	20,6	54,6	0,8	1,9		
	16	002626042	002626142	44,4	109,3	1,1	2,6		



Note:

CH Battery fuse links are used in combination
with fuse disconnecter EFH 10 DC

Dimensions for CH 10x38 Battery fuses

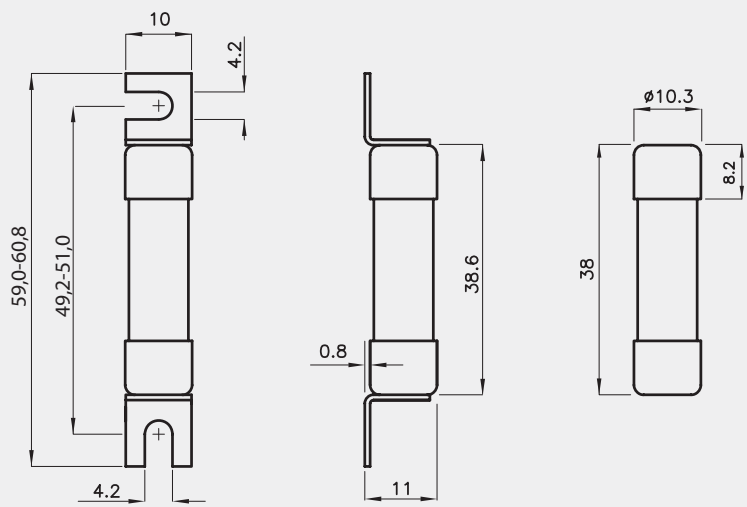

I/t characteristics for CH 10x38 Battery fuses

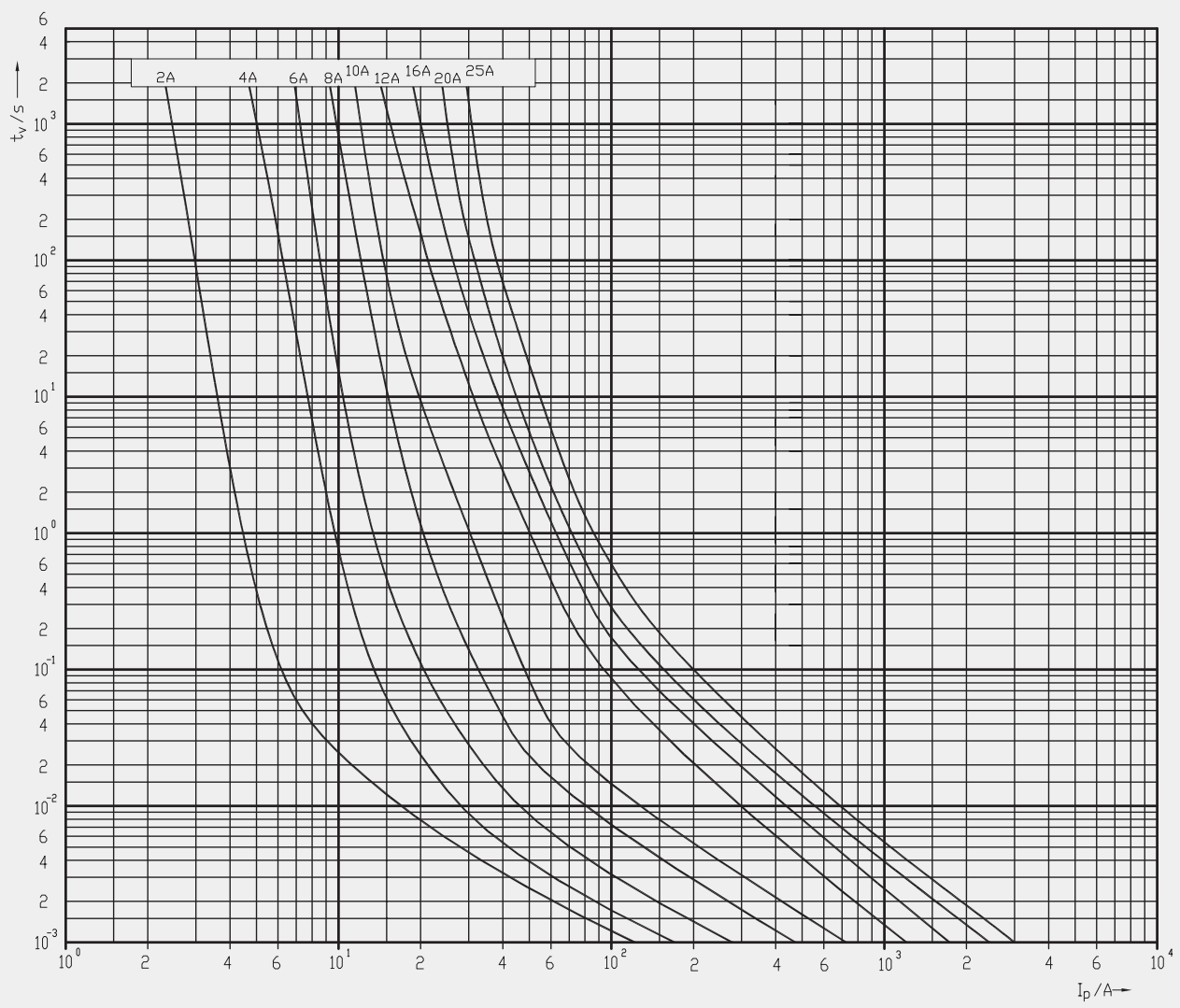

CH 14x51 BATTERY Fuse link 800V d.c.

General characteristics	
Rated voltage	800V d.c. (L/R=10ms)
Breaking capacity	30kA d.c.
Standard	IEC 60269
Application	Battery protection

CH BATTERY fuse link									
Size	I_n [A]	Code No. "standard contacts" 800V DC 30kA	Code No. "type SU contacts" 800V DC 30kA	Pre-arcing Joule integral L/R=10ms [A ² s]	Operating Joule integral L/R=10ms [A ² s]	Power dissipation [0,7 x I_n] P_d [W]	Power dissipation [1x I_n] P_d [W]	Weight [g]	Pack. [pcs]
14x51	16	002637405	002637505	37	136	1,4	3,1	19/21	10/200 SU: 10/260
	20	002637407	002637507	80	284	1,5	3,2		
	25	002637409	002637509	128	438	2	4		
	32	002637411	002637511	296	1050	2,1	5,1		
	36	002637412	002637512	370	1160	2,3	5,6		



Note:

CH Battery fuse links are used in combination
with fuse disconnecter EFH 14 DC

Dimensions for CH 14x51 Battery fuses

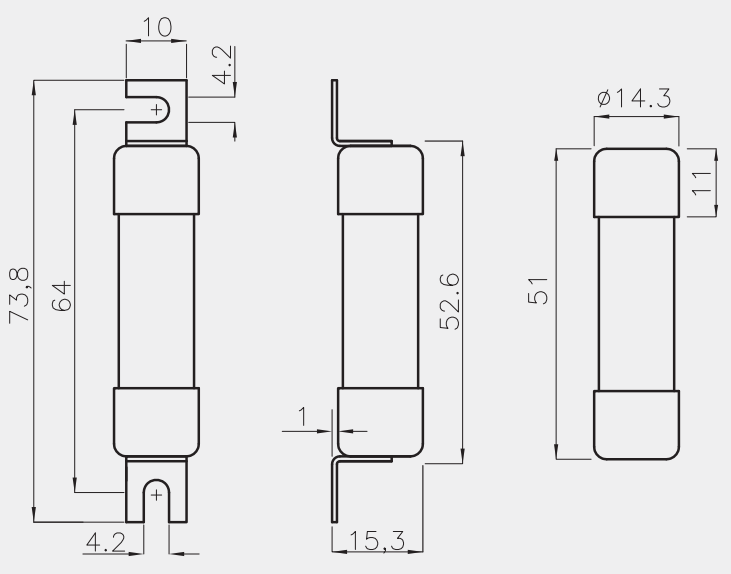

I/t characteristics for CH 14x51 Battery fuses

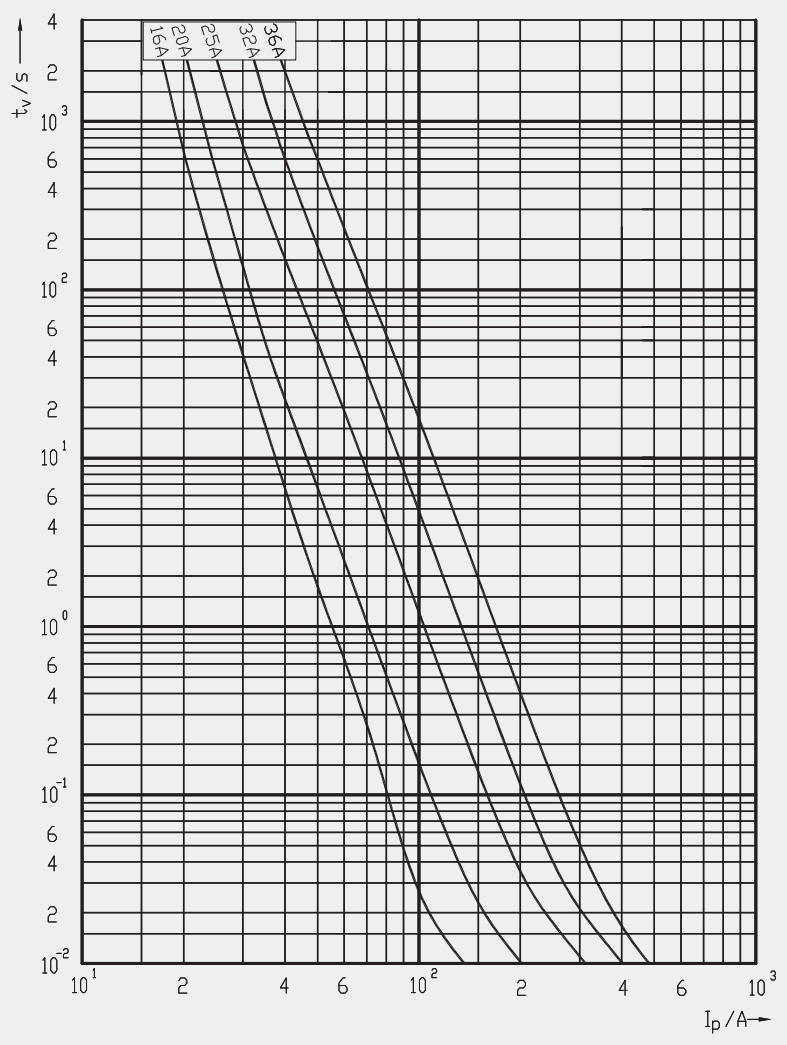

CH fuse holder for DC applications

Technical data				
Fuse type	EFH 10 DC		EFH 14 DC	
	CH 10x38 DC		CH 14x51 DC	
	IEC	UL	IEC	UL
Versions	Without indicator, LED indicator			
Number of poles	1p, 2p, 2p+N+S			
Rated operational voltage Ue	1000V d.c.			
Rated operational current Ie	25A		50A	
Rated conditional short-circuit current	30kA	10kA	30kA	10kA
Rated insulation voltage Ui	1000V		1000V	
Rated imp. withstand voltage Uimp	8kV		8kV	
Required insulation temperature rating		60°C		60°C
Max power dissipation of the fuse-link	3W		5W	
Derating factor of current I _n for different ambient temperatures	20°	1		
	30°	0,95		
	40°	0,9		
	50°	0,8		
	60°	0,7		
	70°	0,5		
Derating factor of current I _n for side by side mounting fuse holders (nr. of poles)	1-4	1		
	5-6	0,8		
	7-9	0,7		
	≥10	0,6		
LED indicator operating range	80V - 1000V d.c.			
Utilization category	Do not operate under load			
Operational performance (cycles with current)	0		0	
Operational performance (cycles without current)	2000		2000	
Inclined Plane Tracking (IPT)		60min / 1kV		60min / 1kV
Humidity	90% / 20°C		90% / 20°C	
Operating ambient temperature	-5°C ... +40°C		-5°C ... +40°C	
Store ambient temperature	-25°C ... +55°C		-25°C ... +55°C	
Degree of protection (IEC 60529)	IP 20		IP 20	
Terminal capacity	1-25mm ²	AWG 18-8, solid&stranded, Cu only	1,5-35mm ²	AWG 16-6, solid&stranded, Cu only
Screw	PZ M5	PZ M5	PZ M5	PZ M5
Torque	2Nm	2Nm, 17,7 lb-in	2,5-3Nm	2Nm, 17,7 lb-in
Mounting on EN 60715 rail	35mm rail			
Sealing possibility	ON and OFF			
Standards - fuse links	IEC/EN 60269-2, IEC/EN 60269-6, UL 284-4	IEC/EN 60269-2, IEC/EN 60269-6, UL 284-4	IEC/EN 60269-2, IEC/EN 60269-6, UL 284-4	UL 248-4, IEC/EN 60269-2
Standards - fuse holders	IEC 60947-1, IEC 60947-3	UL 4248-1*, UL 4248-18*, UL 486E*, CSA C22.2 No.65*	IEC 60947-1, IEC 60947-3	UL 4248-1*, UL 4248-18*, UL 486E*
Test reports	Int	UL	Int	UL
Certificates		UL Listed		UL Listed

*Not for 2p+N+S

EFH 10 DC - Fuse holder

EFH 10 DC							
Number of poles	U_e/U_i [V]	$I_{max.}$ [A]	Code No.	Indicator	Adapter	Weight [g]	Pack. [pcs]
1p	1000V d.c.	25	002540201	-	-	63	12/108
			002540211	LED	-	64	
			002540501	-	✓	68	
			002540511	LED	✓	69	
2p			002540203	-	-	124	6/54
			002540213	LED	-	125	
			002540503	-	✓	134	
			002540513	LED	✓	135	
2p+N+S*			002540204	-	-	257	3/27

*Only IEC certified

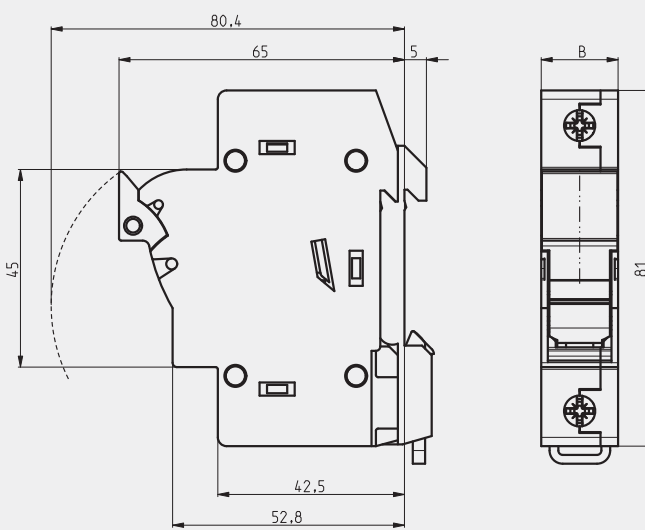
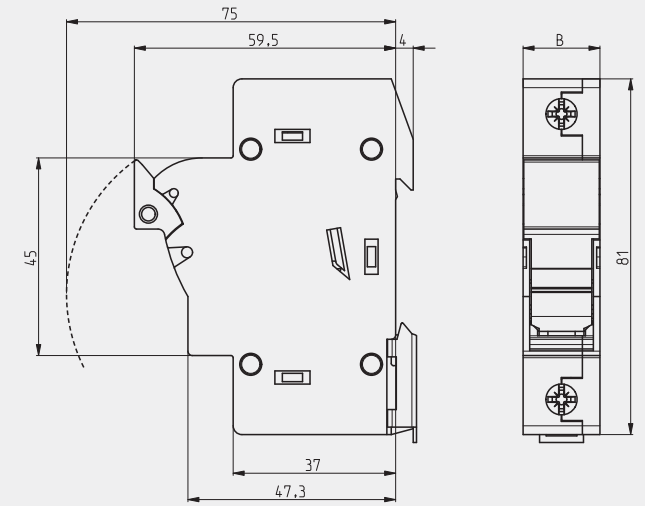

Version with adapter

	B
1p	17,5
2p	35
2p+N+S	70



EFH 14 DC - Fuse holder

EFH 14 DC						
Number of poles	U_e/U_i [V]	$I_{max.}$ [A]	Code No.	Indicator	Weight [g]	Pack. [pcs]
1p	1000V d.c.	50	002560201	-	102	12/96
			002560211	LED	103	
2p			002560203	-	206	6/48
			002560213	LED	208	
2p+N+S*			002560205	-	452	3/24

*Only IEC certified

	B
1p	27
2p	54
2p+N+S	108

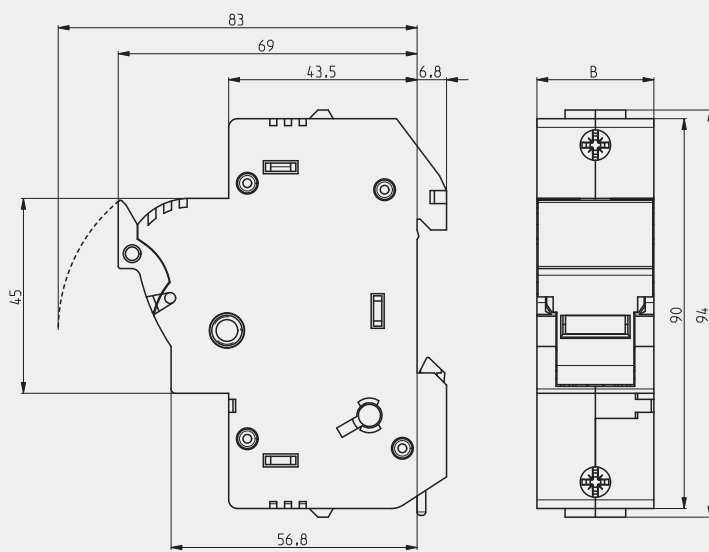

NH BATTERY fuse link 80V d.c.

Low power dissipation and fast characteristic in time range of 5s!

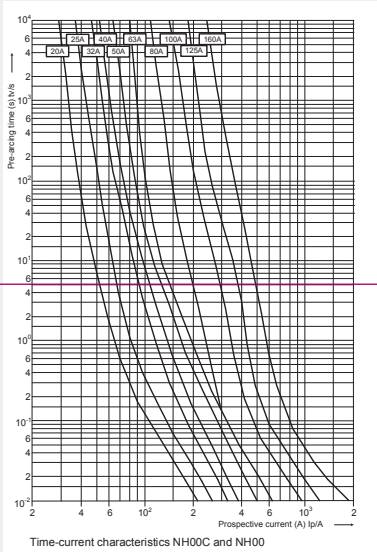

5s

I_k

Discharge	-20~60°C
Charge	-10~60°C
Storage	-20~60°C
Max. Discharge Current 77°F(25°C)	1000A(5s)
Short Circuit Current	3300A
Charge Methods: Constant Voltage Charge 77°F(25°C)	
Cycle use	14.4-14.7V
Maximum charging current	60A
Temperature compensation	-30mV/°C

Better protection of battery cells on overheating in case of short circuit comparable to standard gG characteristic

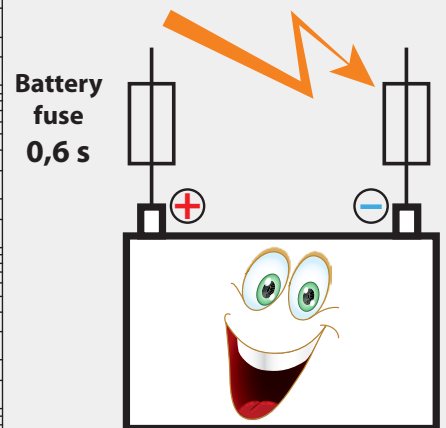
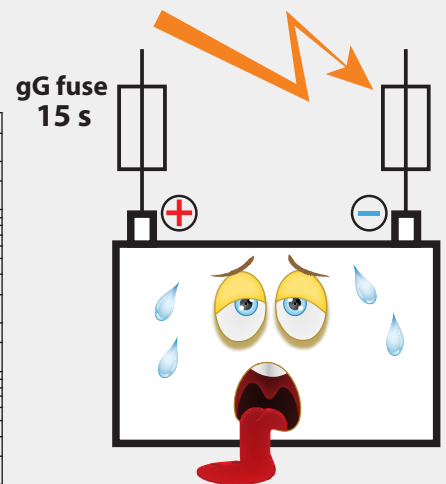
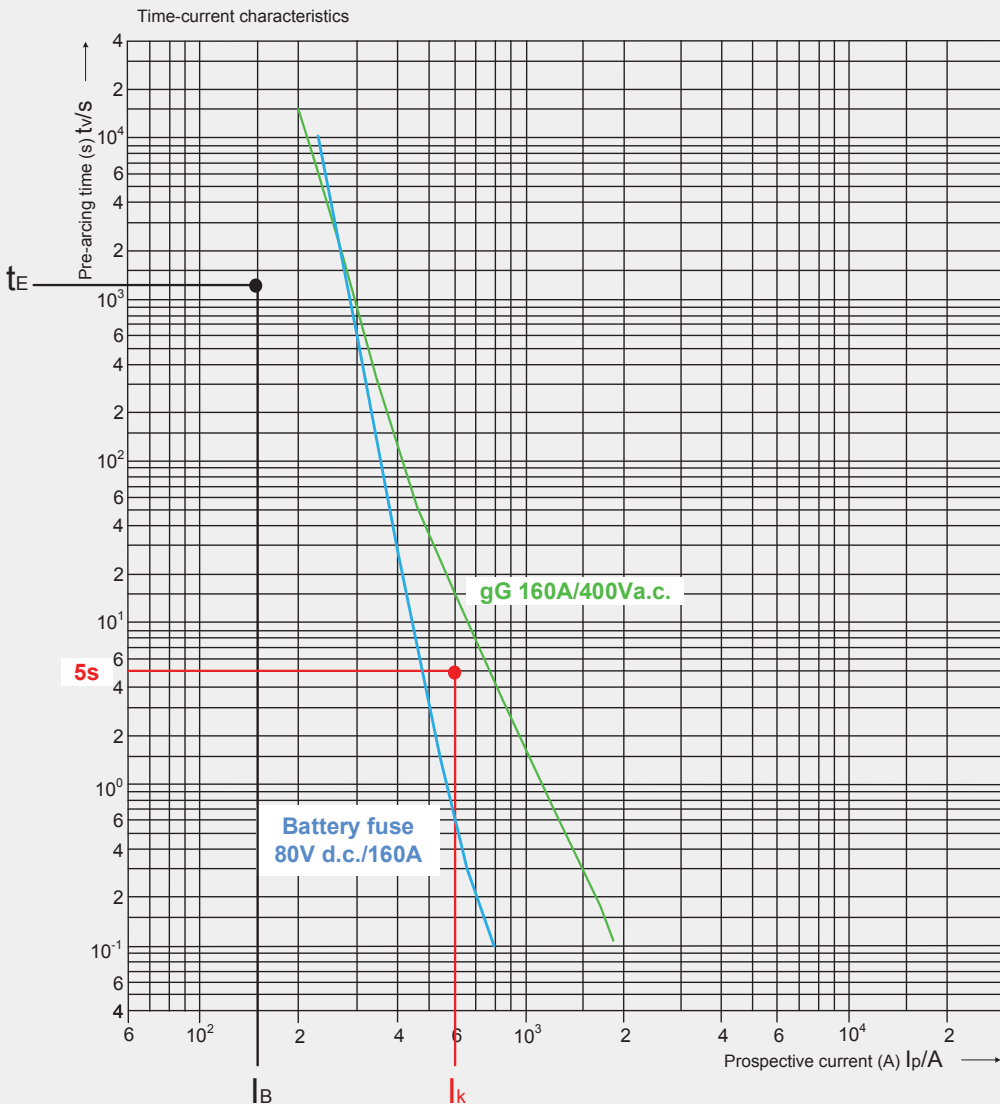

General characteristics

Rated voltage	80V d.c., L/R=10ms
Breaking capacity	30kA d.c..
Standard	IEC 60269
Application	Battery protection

NH 000L Battery fuse link 80V d.c.

Size	I_n [A]	Code No.	Power dissipation [W]	Pre-arcing Joule integral [A ² s]	Operat- ing Joule integral [A ² s]	Weight [g]	Pack. [pcs]
000L	160	004110070	15,5	27.000	30.000	125	3/120

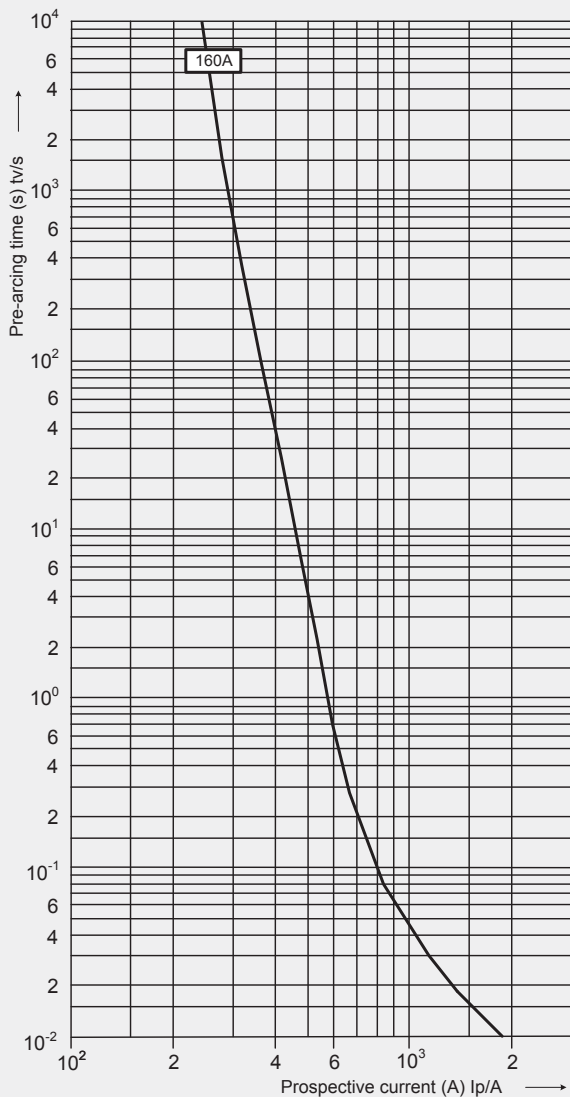

Time-current characteristics NH000L

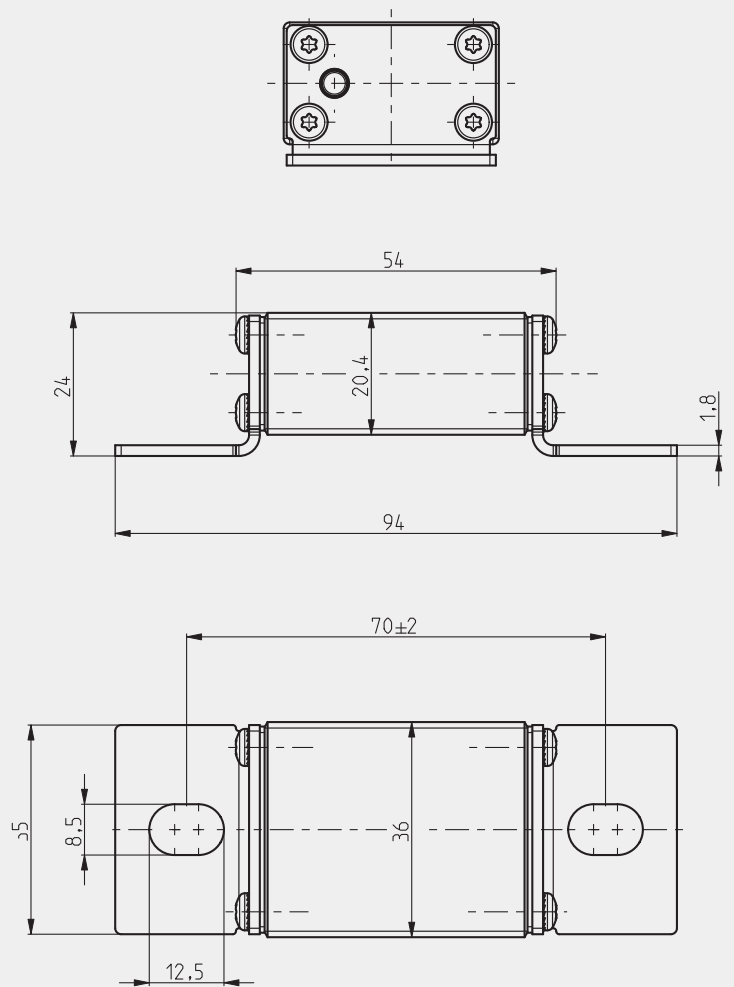

General characteristics	
Rated voltage	80V d.c., L/R=10ms
Breaking capacity	50kA d.c..
Standard	IEC 60269
Application	Battery protection

NH BATTERY fuse link 80V d.c.							
Size	I_n	Standard indicator	Power dissipation	Pre-arcing Joule integral	Operating Joule integral	Weight	Pack.
	[A]	pic. 1	[W]	[A ² s]	[A ² s]	[g]	[pcs]
00C	20	004110075	4,6	360	414	125	3/120
	25	004110076	5,8	710	817		
	32	004110077	6,6	920	1.058		
	40	004110078	9,4	1.440	1.656		
	50	004110079	11,1	2.820	3.243		
00	63	004110080	11,7	4.160	4.784	173	3/90
	80	004110081	10,4	4.670	5.371		
	100	004110082	11,1	9.360	10.764		
	125	004110083	13,4	14.750	16.963		
	160	004110084	15,5	27.880	32.062		
1C	20	004110085	6,3	360	414	233	3/45
	25	004110086	7,3	710	817		
	32	004110087	9	920	1.058		
	40	004110088	11,2	1.440	1.656		
	50	004110089	14,5	2.820	3.243		
	63	004110090	16,8	4.160	4.784		
	80	004110091	11,4	4.670	5.371		
	100	004110092	12	9.360	10.764		
	125	004110093	14,8	14.750	16.963		
1	160	004110094	17,6	27.880	32.062	430	3/24
	200	004110095	26,6	41.990	48.289		
	250	004110096	31	81.000	93.150		



Dimensions

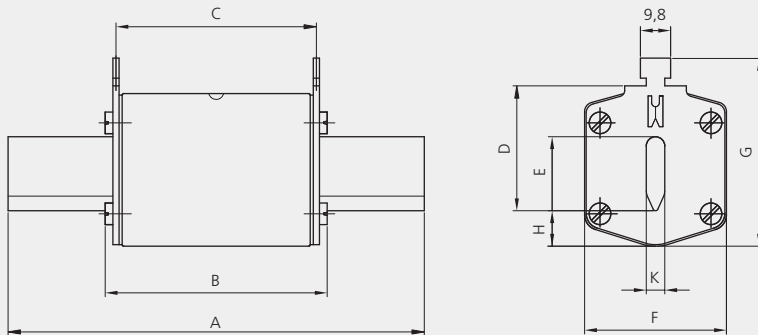

	A	B	C	D	E	F	G	H	K
00 C	79	53	47	35	15	21	52	7,5	6
00	79	53	47	35	15	28	56	12	6
1 C	135	68	65	40	15	28	61	12	6
1	135	72	65	40	20	46	65	14	6

I/t characteristics for NH Battery fuses

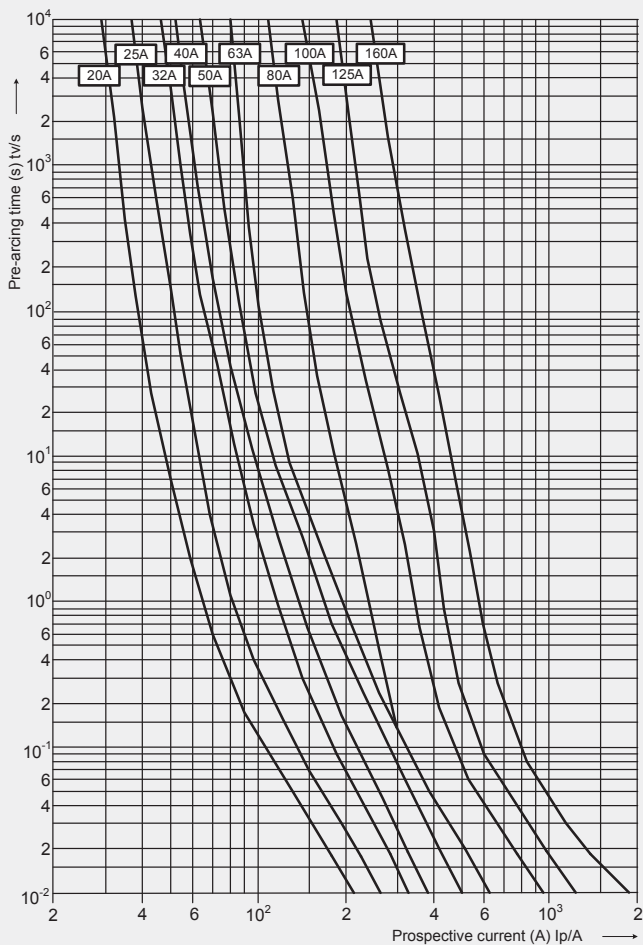

Time-current characteristics NH00C and NH00

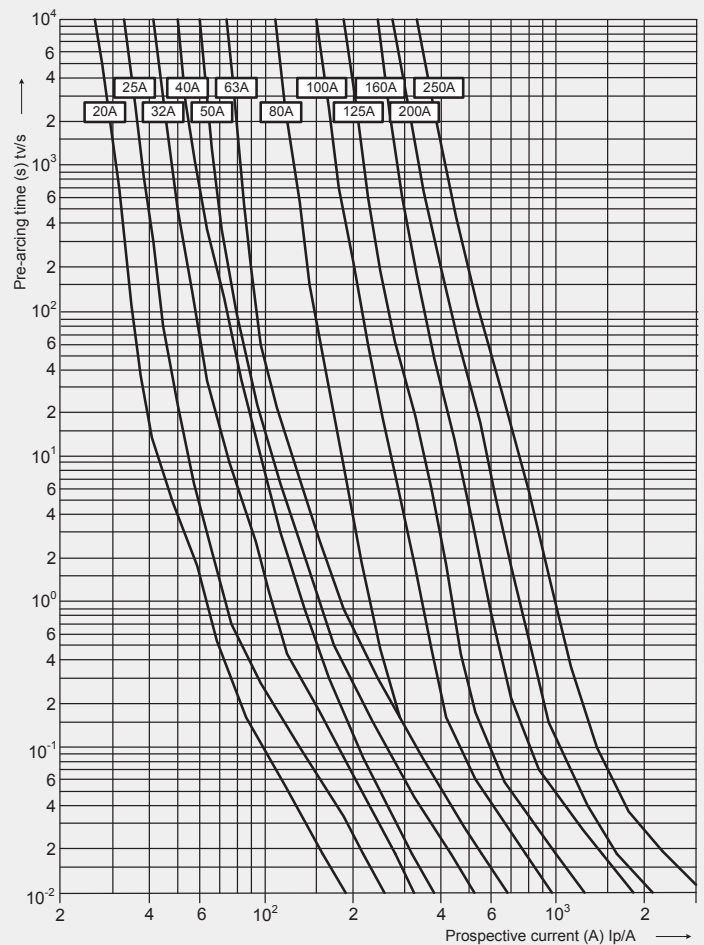

Time-current characteristics NH1C and NH1

NH BATTERY fuse link 440V d.c.

General characteristics	
Rated voltage	440V d.c., L/R=10ms
Breaking capacity	30kA d.c.
Standard	IEC 60269
Application	Battery protection

NH BATTERY fuse link 440 V d.c.							
Size	I_n	Standard indicator	Power dissipation	Pre-arcing Joule integral L/R=10ms	Operating Joule integral L/R=10ms	Weight	Pack.
	[A]		[W]	[A ² s]	[A ² s]	[g]	[pcs]
00	32	004110209	6,6	920	1.656	173	3/90
	40	004110219	9,4	1.440	2.592		
	50	004110218	11,1	2.820	5.076		
	63	004110217	11,7	4.160	7.488		
	80	004110216	10,4	4.670	8.406		
	100	004110215	11,1	9.360	16.848		
1C	20	004723103	6,3	360	648	233	3/45
	25	004723104	7,3	710	1.278		
	32	004723105	9	920	1.656		
	40	004723106	11,2	1.440	2.592		
	50	004723107	14,5	2.820	5.076		
	63	004723108	16,8	4.160	7.488		
	80	004723109	11,4	4.670	8.406		
	100	004723110	12	9.360	16.848		
	125	004723111	14,8	14.750	26.550		
160	004723112	17,6	27.880	50.184			

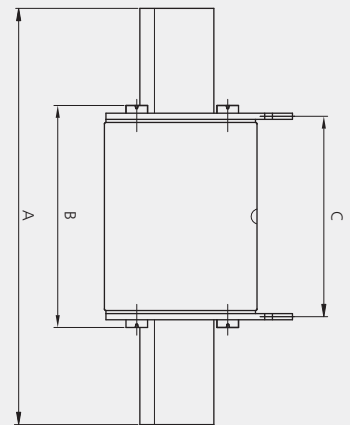

Dimensions

	A	B	C	D	E	F	G	H	K
00	79	53	47	35	15	28	56	12	6
1C	135	68	65	40	15	28	61	12	6

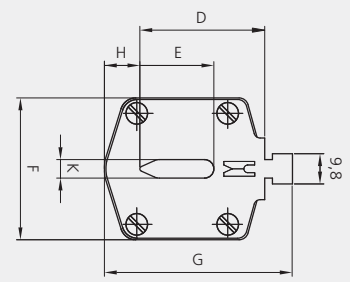

I/t characteristics

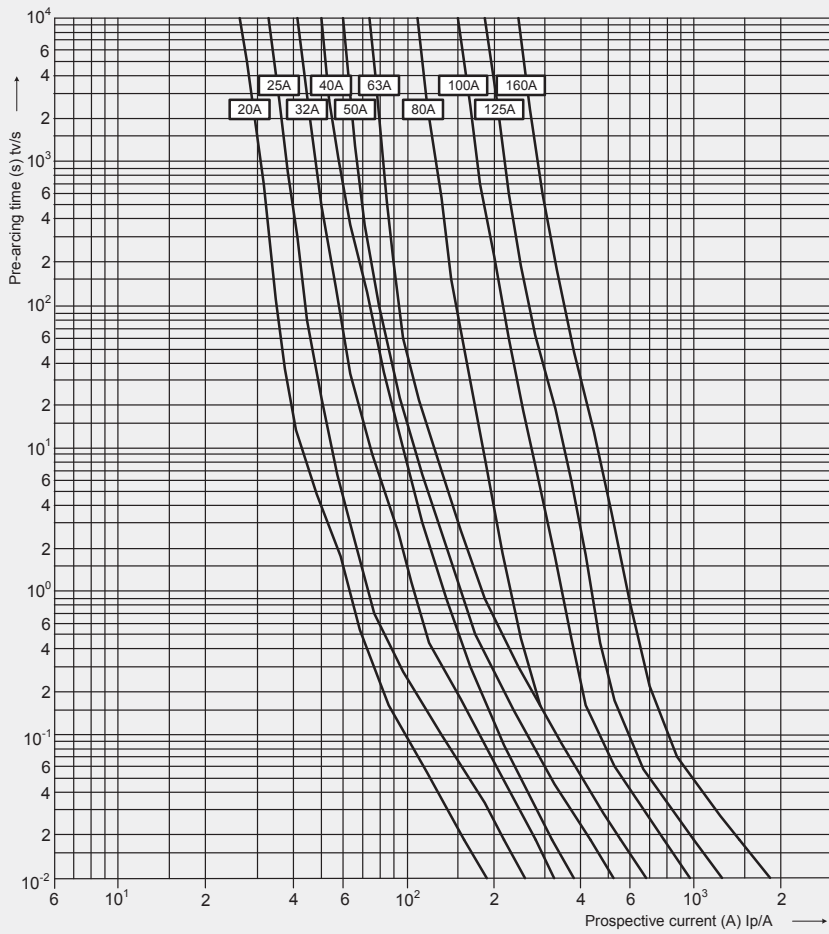

Application

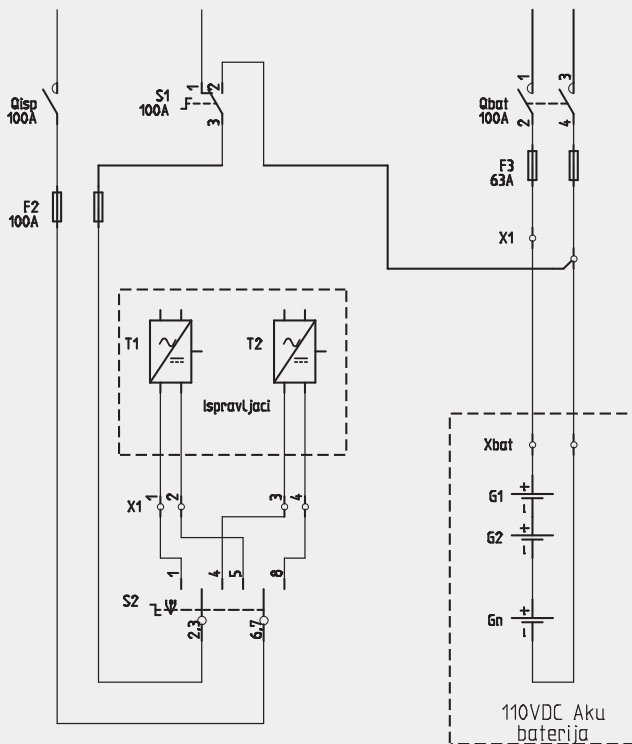

NH BATTERY fuse link 550V d.c.



General characteristics	
Rated voltage	550V d.c. (L/R=10ms)
Breaking capacity	30kA d.c.
Standard	IEC 60269
Application	Battery protection

NH BATTERY fuse link 550 V d.c.									
Size	I_n	Standard indicator	Striker indicator	Standard indicator S110mm	Power dissipation	Prearcing Joule integral L/R=10ms	Operating Joule integral L/R=10ms	Weight	Pack.
	[A]	pic. 1	pic. 1	pic. 2	[W]	[A ² s]	[A ² s]	[g]	[pcs]
1	40	004723259	004723279	004723269	6	250	833	420	3/24
	50	004723260	004723280	004723270	7	449	1.495		
	63	004723261	004723281	004723271	9	700	2.331		
	80	004723262	004723282	004723272	12	1.200	3.996		
	100	004723263	004723283	004723273	15	1.650	5.495		
	125	004723264	004723284	004723274	20	2.200	7.326		
	160	004723265	004723285	004723275	26	4.300	14.319		
	200	004723266	004723286	004723276	32	8.500	28.305		
	224	004723267	004723287	004723277	37	10.000	33.300		
	250	004723268	004723288	004723278	43	15.000	50.000		
2	125	004724260	004724280	004724270	20	2.200	10.296	660	3/24
	160	004724261	004724281	004724271	26	4.300	20.124		
	200	004724262	004724282	004724272	32	8.500	39.780		
	224	004724263	004724283	004724273	37	10.000	46.800		
	250	004724264	004724284	004724274	43	15.000	70.200		
	315	004724265	004724285	004724275	57	20.000	93.600		
	350	004724266	004724286	004724276	67	28.000	131.040		
3	400	004724267	004724287	004724277	76	32.000	150.000	870	3/24
	250	004725260	004725280	004725270	43	15.000	65.550		
	315	004725261	004725281	004725271	57	20.000	87.400		
	350	004725262	004725282	004725272	67	28.000	122.360		
	400	004725263	004725283	004725273	76	32.000	139.840		
	425	004725264	004725284	004725274	84	40.000	174.800		
	500	004725265	004725285	004725275	110	44.000	192.280		
	630	004725266	004725286	004725276	160	80.000	350.000		

NH BATTERY fuse link 700V d.c.

General characteristics	
Rated voltage	700V d.c. (L/R=10ms)
Breaking capacity	30kA d.c.
Standard	IEC 60269
Application	Battery protection



NH BATTERY fuse link 700 V d.c.									
Size	I_n	Standard indicator	Striker indicator	Standard indicator S110mm	Power dissipation	Pre-arcing Joule integral L/R=10ms	Operating Joule integral L/R=10ms	Weight	Pack.
	[A]	pic. 1	pic. 1	pic. 2	[W]	[A ² s]	[A ² s]	[g]	[pcs]
1	40	004723289	004723309	004723299	6	250	1.000	420	3/24
	50	004723290	004723310	004723300	7	449	1.796		
	63	004723291	004723311	004723301	9	700	2.800		
	80	004723292	004723312	004723302	12	1.200	4.800		
	100	004723293	004723313	004723303	15	1.650	6.600		
	125	004723294	004723314	004723304	20	2.200	8.800		
	160	004723295	004723315	004723305	26	4.300	17.200		
	200	004723296	004723316	004723306	32	8.500	34.000		
	224	004723297	004723317	004723307	37	10.000	40.000		
	250	004723298	004723318	004723308	43	15.000	60.000		
2	125	004724290	004724310	004724300	20	2.200	11.682	660	3/24
	160	004724291	004724311	004724301	26	4.300	22.833		
	200	004724292	004724312	004724302	32	8.500	45.135		
	224	004724293	004724313	004724303	37	10.000	53.100		
	250	004724294	004724314	004724304	43	15.000	79.650		
	315	004724295	004724315	004724305	57	20.000	106.200		
	350	004724296	004724316	004724306	67	28.000	148.680		
3	400	004724297	004724317	004724307	76	32.000	170.000	870	3/24
	250	004725290	004725304	004725297	43	15.000	75.000		
	315	004725291	004725305	004725298	57	20.000	100.000		
	350	004725292	004725306	004725299	67	28.000	140.000		
	400	004725293	004725307	004725300	76	32.000	160.000		
	425	004725294	004725308	004725301	84	40.000	200.000		
	500	004725295	004725309	004725302	110	44.000	220.000		
630	004725296	004725310	004725303	160	80.000	400.000			

NH BATTERY fuse link 800V d.c.

General characteristics	
Rated voltage	800V d.c. (L/R=10ms)
Breaking capacity	30kA d.c.
Standard	IEC 60269
Application	Battery protection



NH BATTERY fuse link 800 V d.c.									
Size	I_n	Standard indicator	Striker indicator	Standard indicator S110mm	Power dissipation	Pre-arcing Joule integral L/R=10ms	Operating Joule integral L/R=10ms	Weight	Pack.
	[A]	pic. 1	pic. 1	pic. 2	[W]	[A ² s]	[A ² s]	[g]	[pcs]
1	40	004723320	004723330	004723340	6	250	1.750	420	3/24
	50	004723321	004723331	004723341	7	449	3.143		
	63	004723322	004723332	004723342	9	700	4.900		
	80	004723323	004723333	004723343	12	1.200	8.400		
	100	004723324	004723334	004723344	15	1.650	11.550		
	125	004723325	004723335	004723345	20	2.200	15.400		
	160	004723326	004723336	004723346	26	4.300	30.100		
	200	004723327	004723337	004723347	32	8.500	60.000		
2	125	004724320	004724330	004724340	20	2.200	13.046	660	3/24
	160	004724321	004724331	004724341	26	4.300	25.499		
	200	004724322	004724332	004724342	32	8.500	50.405		
	224	004724323	004724333	004724343	37	10.000	59.300		
	250	004724324	004724334	004724344	43	15.000	88.950		
	315	004724325	004724335	004724345	57	20.000	118.600		
	350	004724326	004724336	004724346	67	28.000	166.040		
400	004724327	004724337	004724347	76	32.000	190.000			
3L*	500	004110350	-	-	112	150.000	300.000	1970	1/10

*Pic 3

Dimensions

pic. 1

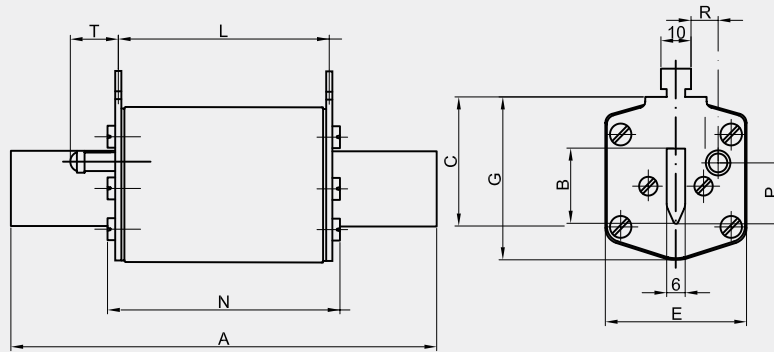

	A	B	C	E	G	S	L	N	P	R	T
1	135	24	40	46	52	6	65	73	20,5	13,7	27,5
2	150	30	48	54	61	6	65	73	27,3	16,2	27,5
3	150	37	60	64	74	6	65	73	35,6	17	27,5

pic. 2

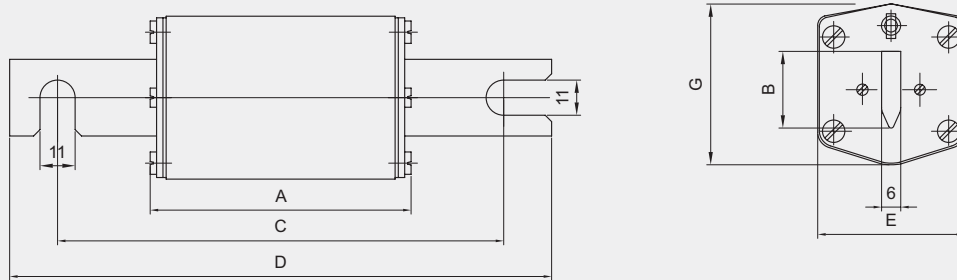

	A	B	C	D	E	G
1	72	24	110	140	46	51
2	72	30	110	140	54	59
3	72	37	110	140	64	70

I/t characteristics for NH Battery fuses sizes 1, 2, 3

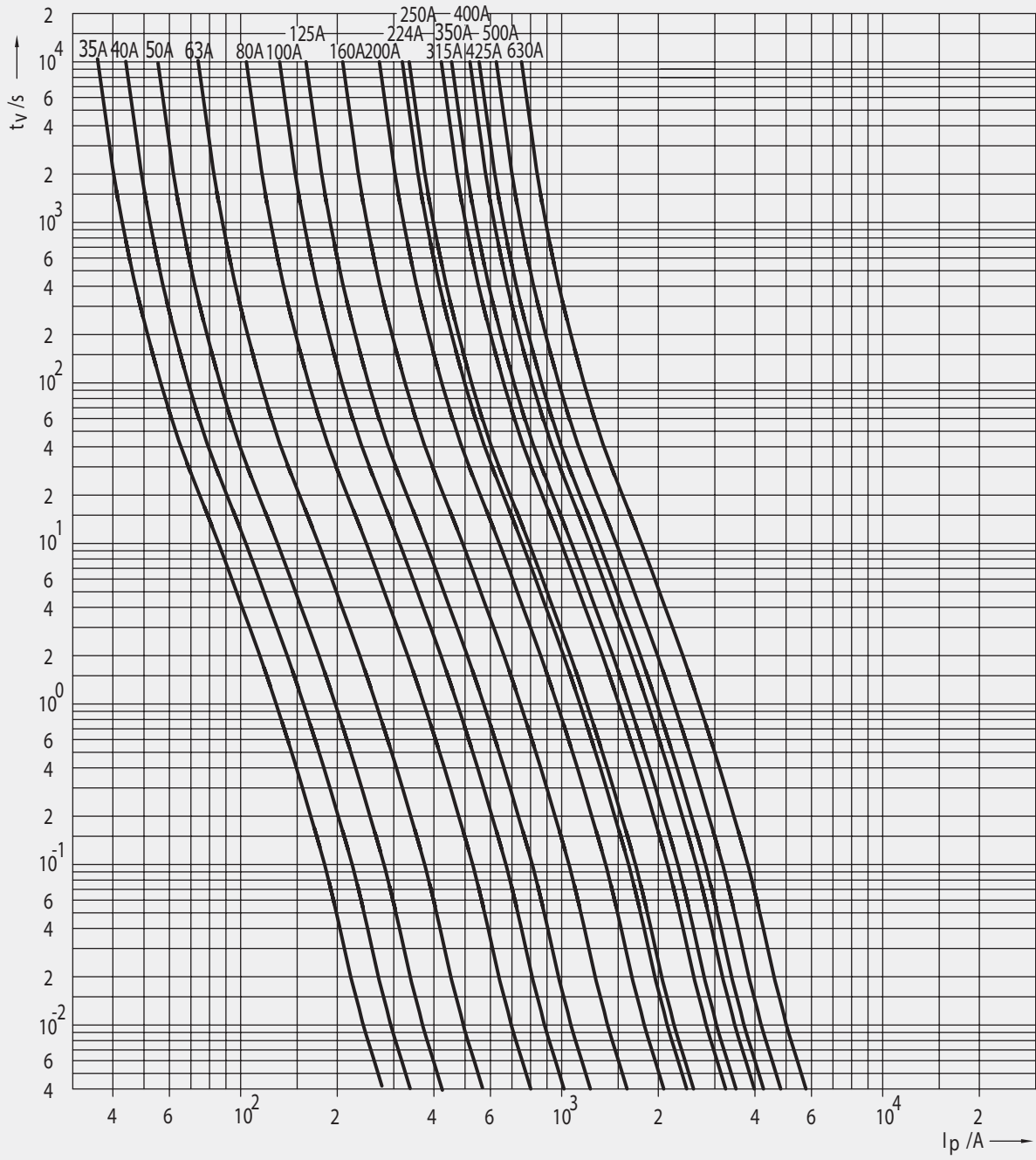

pic.3

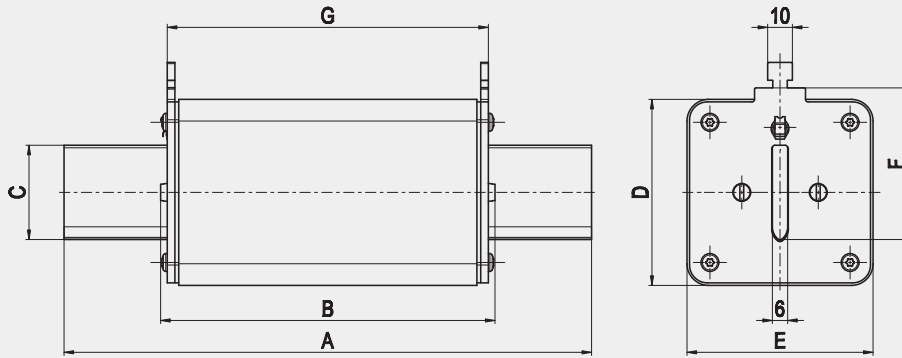

	A	B	C	D	E	F	G	H	J
3L	208	130	37	73	73	60	126	11	13

I/t characteristics for NH Battery fuses size 3L

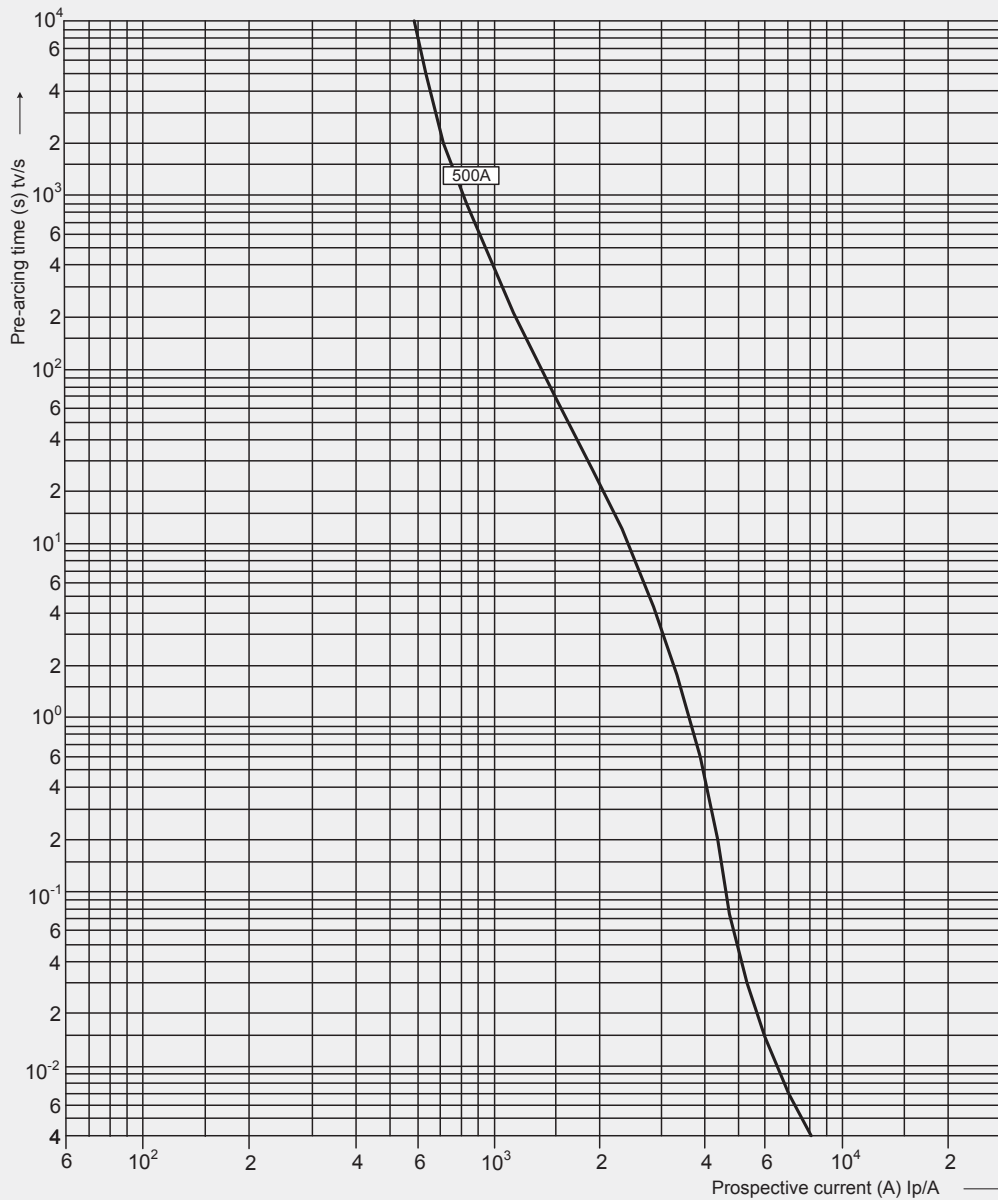

Horizontal fuse-switch disconnecter type HVL for DC applications

Technical data (in accordance with IEC/EN 60947-3 and VDE 0660, part 107)											
Technical specifications			Size 00			Size 1			Size 3		
Technical characteristics											
Rated operational voltage	Ue	V	DC220	DC440	DC1000	DC220	DC440	DC1000	DC220	DC440	DC1000
Rated operational current	Ie	A	160	100	160	250	200	250	630	500	630
Rated insulation voltage	Ui	V	AC800			AC800			AC800		
Total power loss (without fuse)	Pv	W	6,2	2,7	7	8,6	5,5	13	34,6	21,8	52
Utilisation category	-	-	DC22B	DC21B	DC20B	DC22B	DC21B	DC20B	DC22B	DC21B	DC20B
Fuse links											
Size-DIN43620	-	-	00			1			3		
Max. rated current	In	A	160	100	160	250	200	250	630	500	630
Max. permissible power loss per fuse link	Py	W	12			23			48		
Screw	-	-	M8			M10			M10		
Torque	Ma	Nm	12-15			30-35			30-35		
V-clip	-	mm ²	1,5 - 70			25-150			25-240		
Torque	Ma	Nm	2,6			9,5			23		
Protection											
Front cover close	-	-	IP20			IP20			IP20		
Front cover open	-	-	IP 10			IP 10			IP 10		
Operating condition											
Ambient temperature	Tu	°C	-25°C ... +55°C								
Operating condition	-	-	continuous operation								
Mounting	-	-	vertical, horizontal								
Altitude	-	m	≤ 2000								
Pollution degree overvoltage category	-	-	3								

* Switching operations at 1000V DC are not allowed under load

1-pole horizontal fuse-switch disconnecter for baseplate mounting

For size	Code No.	Type	Weight [kg]	Packaging [pcs]
00	001692492	HVL 00 1p M8-M8	0,45	1/1
1	001692494	HVL 1 1p M10-M10	1,5	1/1
3	001692496	HVL 3 1p M10-M10	1,9	1/1

* see also table of accessories for HVL

** for fuse size NH 2 use HVL 3



2-pole horizontal fuse-switch disconnecter for baseplate mounting

For size	Code No.	Type	Weight [kg]	Packaging [pcs]
00	001692501	HVL00 2p M8-M8	0,74	1/1
1	001692502	HVL1 2p M10-M10	2,17	1/1
3	001692503	HVL3 2p M10-M10	4,11	1/1

* see also table of accessories for HVL

** for fuse size NH 2 use HVL 3



3-pole horizontal fuse-switch disconnecter for baseplate mounting

For size	Code No.	Type	Weight [kg]	Packaging [pcs]
0	001692700	HVL 00 3-p M8-M8	0,72	1/1
1	001692705	HVL 1 3-p M10-M10	2,5	1/1
2	001692570	HVL 2 3-p M10-M10	3,1	1/1
3	001692580	HVL 3 3-p M10-M10	4,8	1/1

* see also table of accessories for HVL

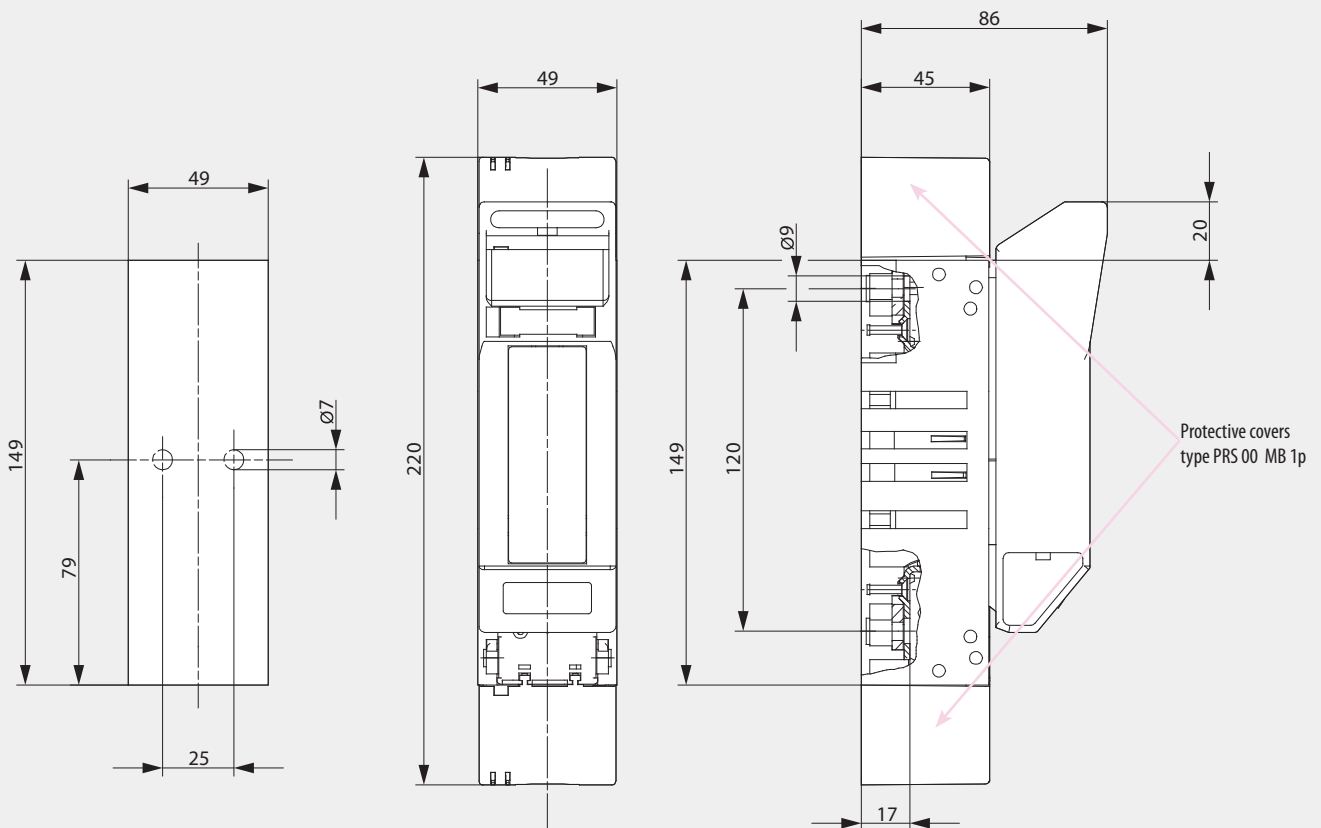

HVL 00 1-p

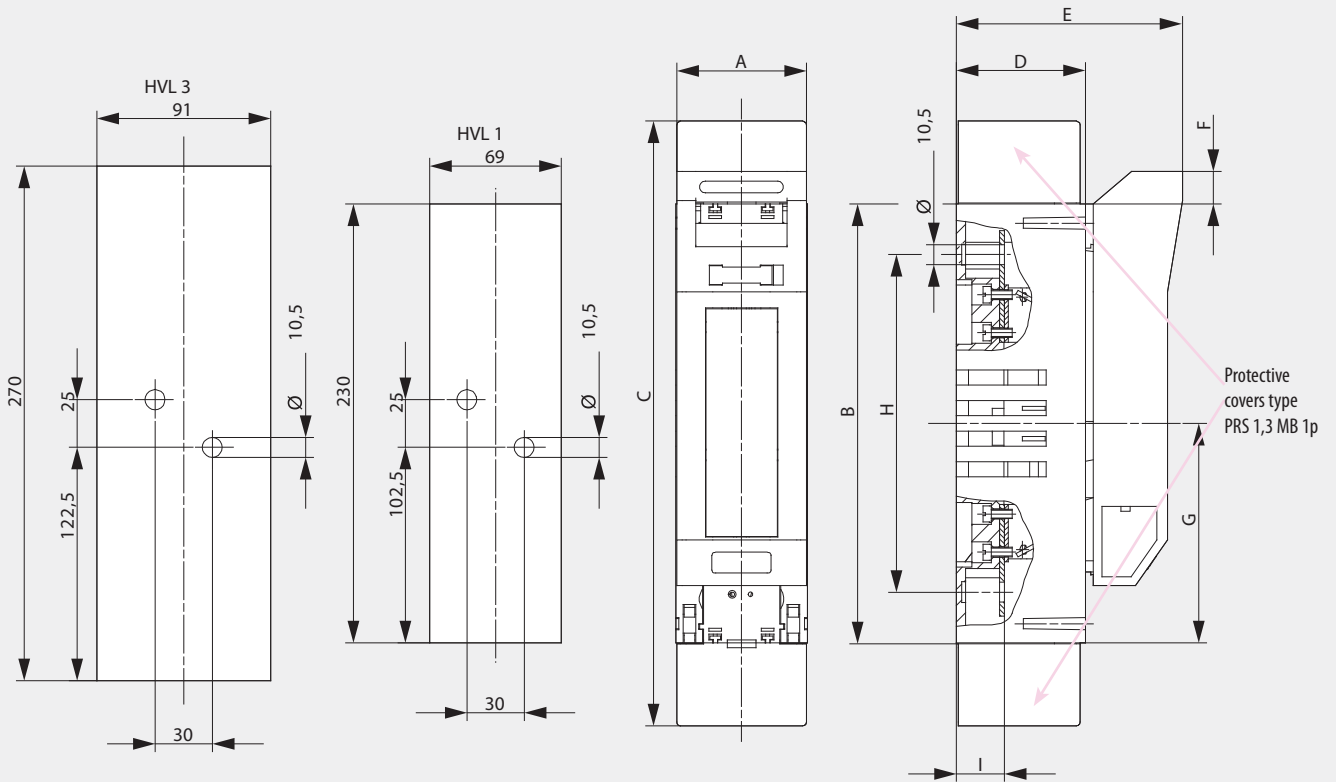

HVL 1 & HVL 3

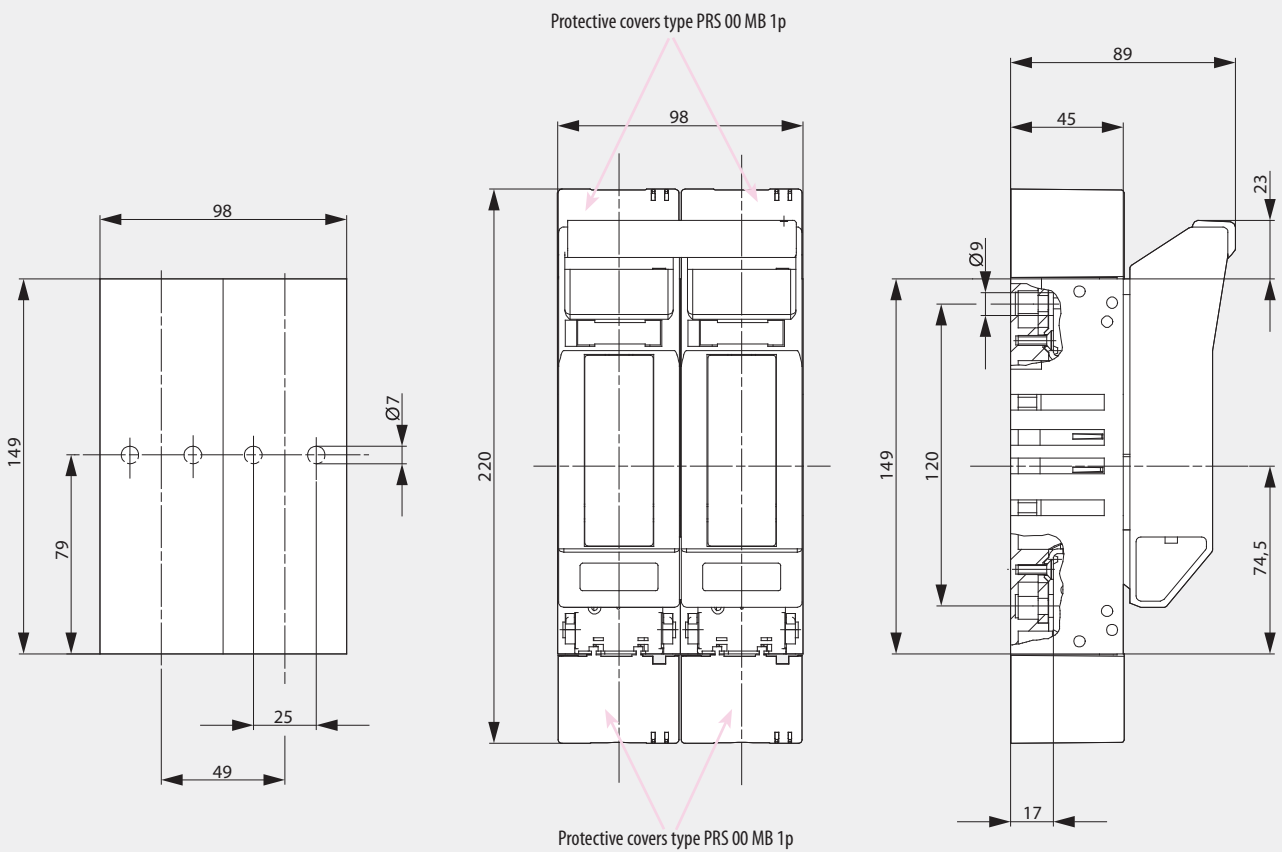

Protective covers type PRS 00 MB 1p

HVL00 2P M8-M8

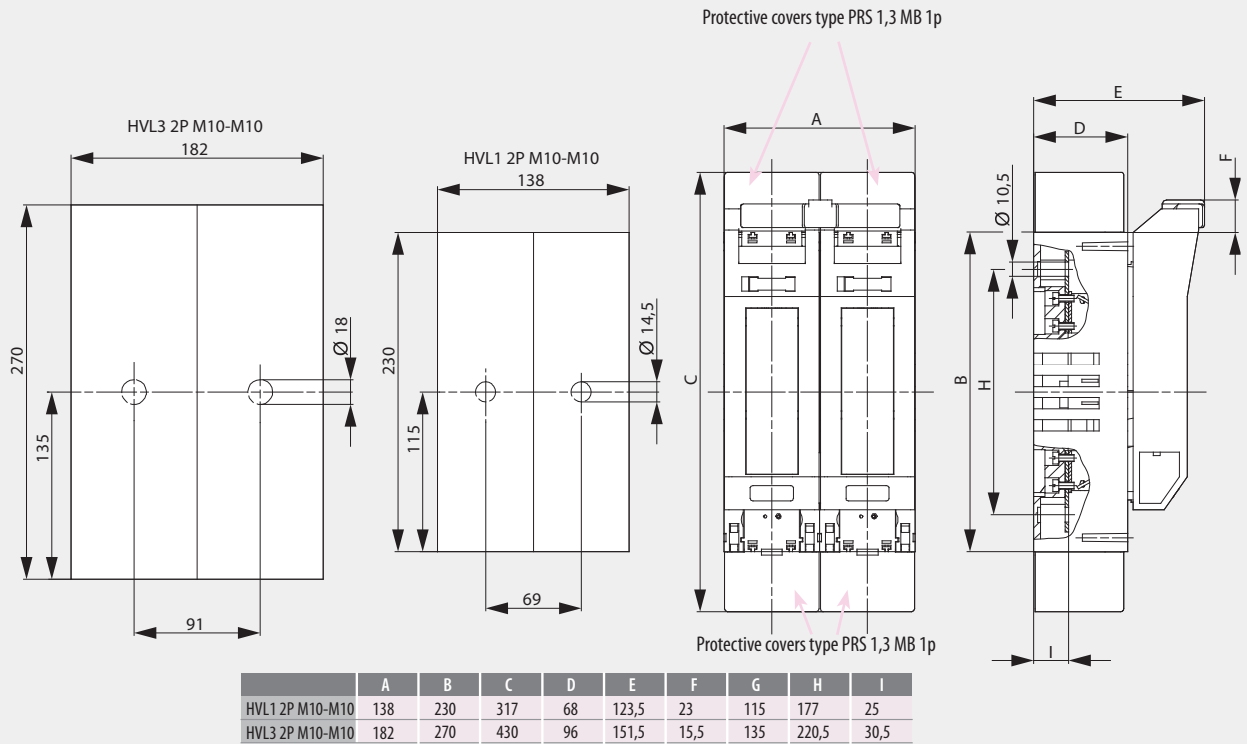

HVL1, 3 2P M10-M10

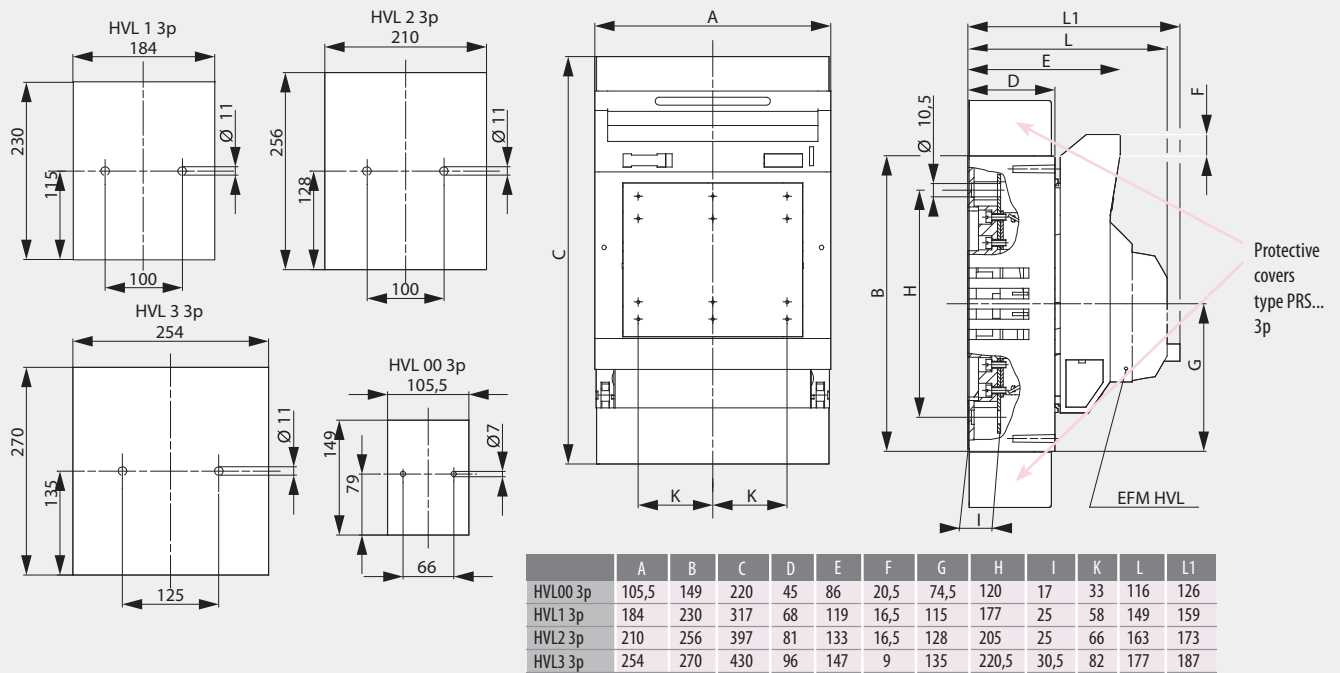

HVL00,1,2,3 - 3p

Accessories for HVL

Type	Code No.	Description	Packaging [pcs]
SP HVL00	001692701	Clip terminal, 1,5 – 50 mm ² Cu	3
SP HVL1	001692702	Clip terminal, 25– 150 mm ² Cu	3
SP HVL3	001692704	Clip terminal, 11x21 mm ² Cu	3
SP HVL00 P1	001692760	Prism clamp, 10 – 70 mm ² Al/Cu	3
SP HVL1 P1	001692761	Prism clamp, 70 – 150 mm ² Al/Cu	3
SP HVL3 P1	001692763	Prism clamp, 120 – 300 mm ² Al/Cu	3
SP HVL1 P2	001692764	Prism clamp for 2-conductors connection, 2x70 – 95 mm ² Al/Cu	3
SP HVL3 P2	001692766	Prism clamp for 2-conductors connection, 2x120 – 240 mm ² Al/Cu	3
MST 00 1p+3p	001692711	Switch position indicator for fuse switch disconnecter size 00, 1p/3p	1
MST 1-3 1p	001692712	Switch position indicator for fuse switch disconnecter size 1-3, 1p	1
MST 1-3 3p	001692713	Switch position indicator for fuse switch disconnecter size 1-3, 3p	1
K-HVL00-1/H	001692718	Mechanical fuse monitor, size 00, 1p	1
K-HVL00-3/H	001692708	Mechanical fuse monitor, size 00, 3p	1
K-HVL1-1/H	001692719	Mechanical fuse monitor, size 1, 1p	1
K-HVL1-3/H	001692715	Mechanical fuse monitor, size 1, 3p	1
K-HVL3-1/H	001692720	Mechanical fuse monitor, size 3, 1p	1
K-HVL3-3/H	001692717	Mechanical fuse monitor, size 3, 3p	1
PRS 00	001692721	Protective cover, 3-pole, baseplate mounting, top/bottom	1
PRS 1 TOP	001692722	Protective cover, 3-pole, baseplate mounting, top	1
PRS 1 BOTTOM	001692725	Protective cover, 3-pole, baseplate mounting, bottom	1
PRS 3 TOP	001692724	Protective cover, 3-pole, baseplate mounting, top	1
PRS 3 BOTTOM	001692727	Protective cover, 3-pole, baseplate mounting, bottom	1
PRS 00 MB 1p	001696120	Protective cover, 1-pole, baseplate- and busbar mounting, top/bottom	1
PRS 1 MB 1p	001696121	Protective cover, 1-pole, baseplate- and busbar mounting, top/bottom	1
PRS 3 MB 1p	001696122	Protective cover, 1-pole, baseplate- and busbar mounting, top/bottom	1



SP HVL ...



SP HVL ... P1



K-HVL00-1/H
K-HVL1-1/H
K-HVL3-1/H



K-HVL00-3/H
K-HVL1-3/H
K-HVL2-3/H
K-HVL3-3/H



MST 00 1p+3p
MST 1-3 1p
MST 1-3 3p



SP HVL ... P2



SP HVL ... D

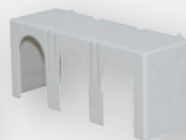

PRS 00 3p
PRS ... top/bottom 3p

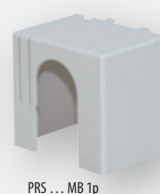

PRS ... MB 1p

How to choose the correct Battery fuse - example

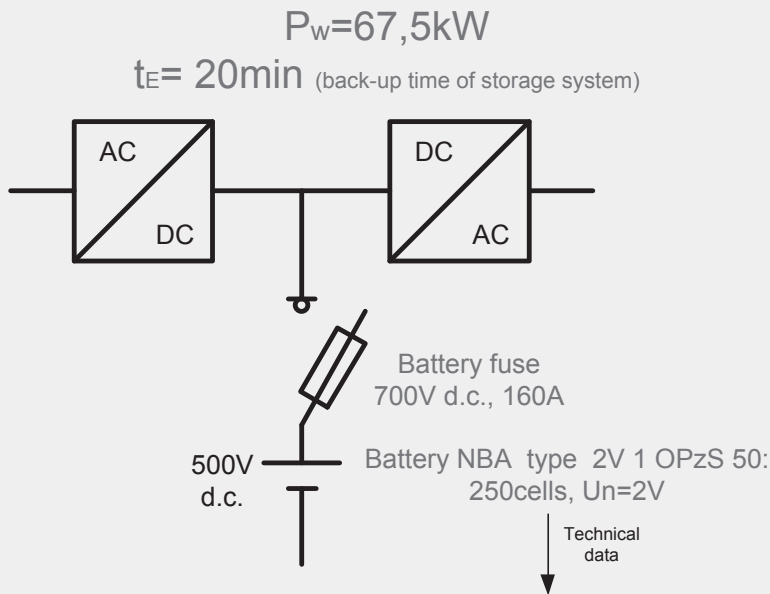

1. Short circuit point (I_k):

2. Types, capacities, dimensions, mass

Type	C10	C5	C3	C1	RI 1)	I_k 2)	length	width	height max	mass 3)	mass 4)
	Ah	Ah	Ah	Ah	mΩ	kA	mm	mm	mm	kg	kg
<u>U_e (V/cell)</u>	<u>1,80</u>	1,77	1,75	1,67							
2V 1 OPzS 50	50	45	36	24	3,96	0,58	103	206	426	4,5	7
2V 2 OPzS 100	100	85	66	48	1,98	1,16	103	206	426	7,5	6,5
2V 3 OPzS 150	150	125	102	72	1,27	1,74	103	206	426	10	6
2V 4 OPzS 200	200	170	138	96	1,01	2,06	103	206	426	12	6
2V 5 OPzS 250	250	210	171	120	0,81	2,57	124	206	426	14	7,5
2V 6 OPzS 300	300	250	204	144	0,69	3,14	145	206	426	16	9
6V 3 OPzS 150	150	125	107	75	3,71	0,62	233	224	426	23,5	13,5

1, 2) internal resistance and short - circuit - current according to IEC 896-1 3) dry-charged 4) filled and charged



$I_k = 580\text{A}$

2. Operating point (t_E/I_B):

$t_E = 20\text{min}$ (1200s)

$U_E = 250\text{cells} \times 1,8\text{V} = 450\text{V d.c.}$

$I_B = P_w/U_E = 67,5\text{kW} / 450\text{V} = 150\text{A}$

3. DC rated fuse link:

Battery fuse 700V d.c., L/R=10ms

NH00 gG 160A 690V a.c.....problem DC rating at min. breaking capacity $\sim 2 \times I_n$???

1. Short circuit point (I_k):

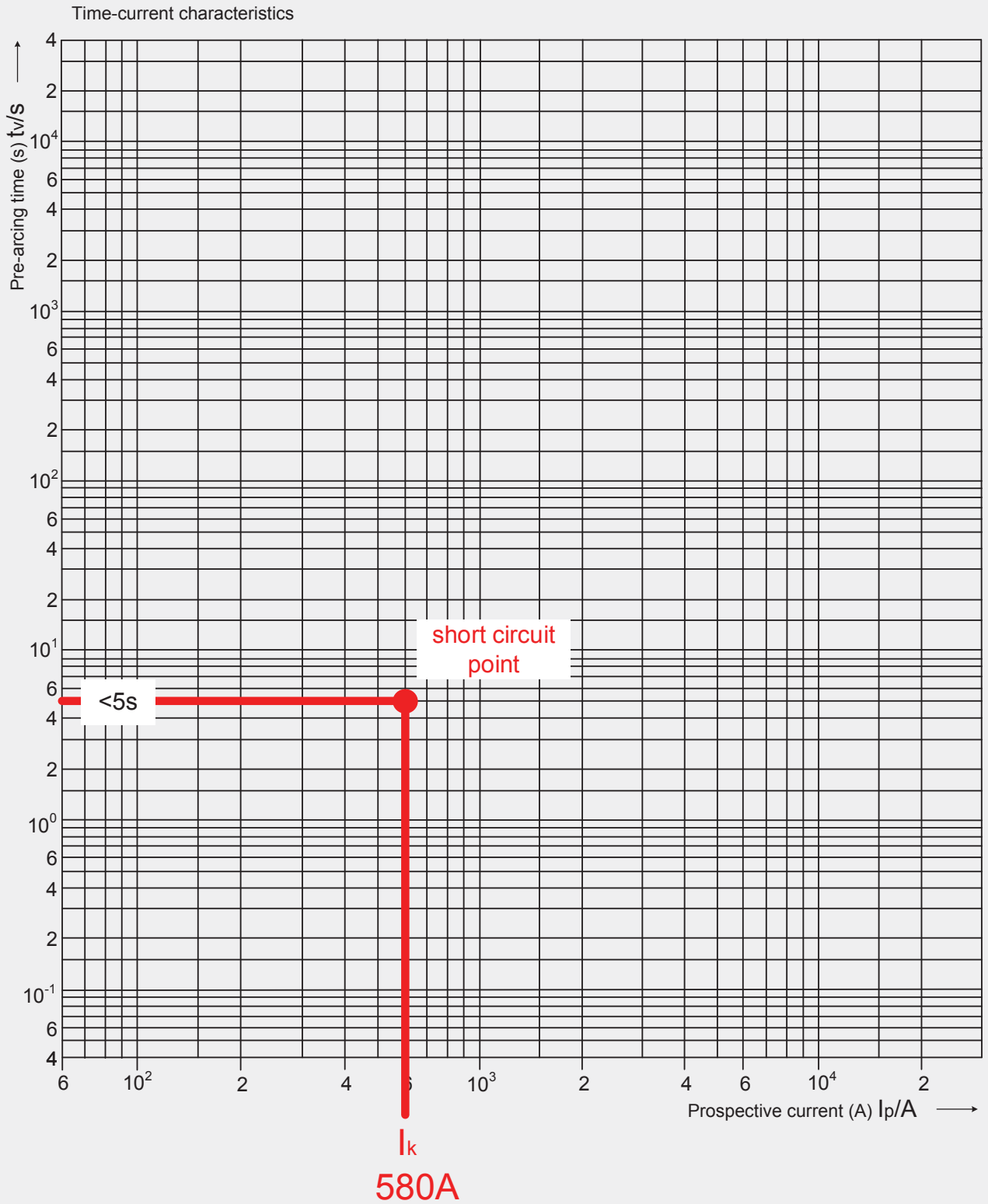

2. Operating point (t_E/I_B):

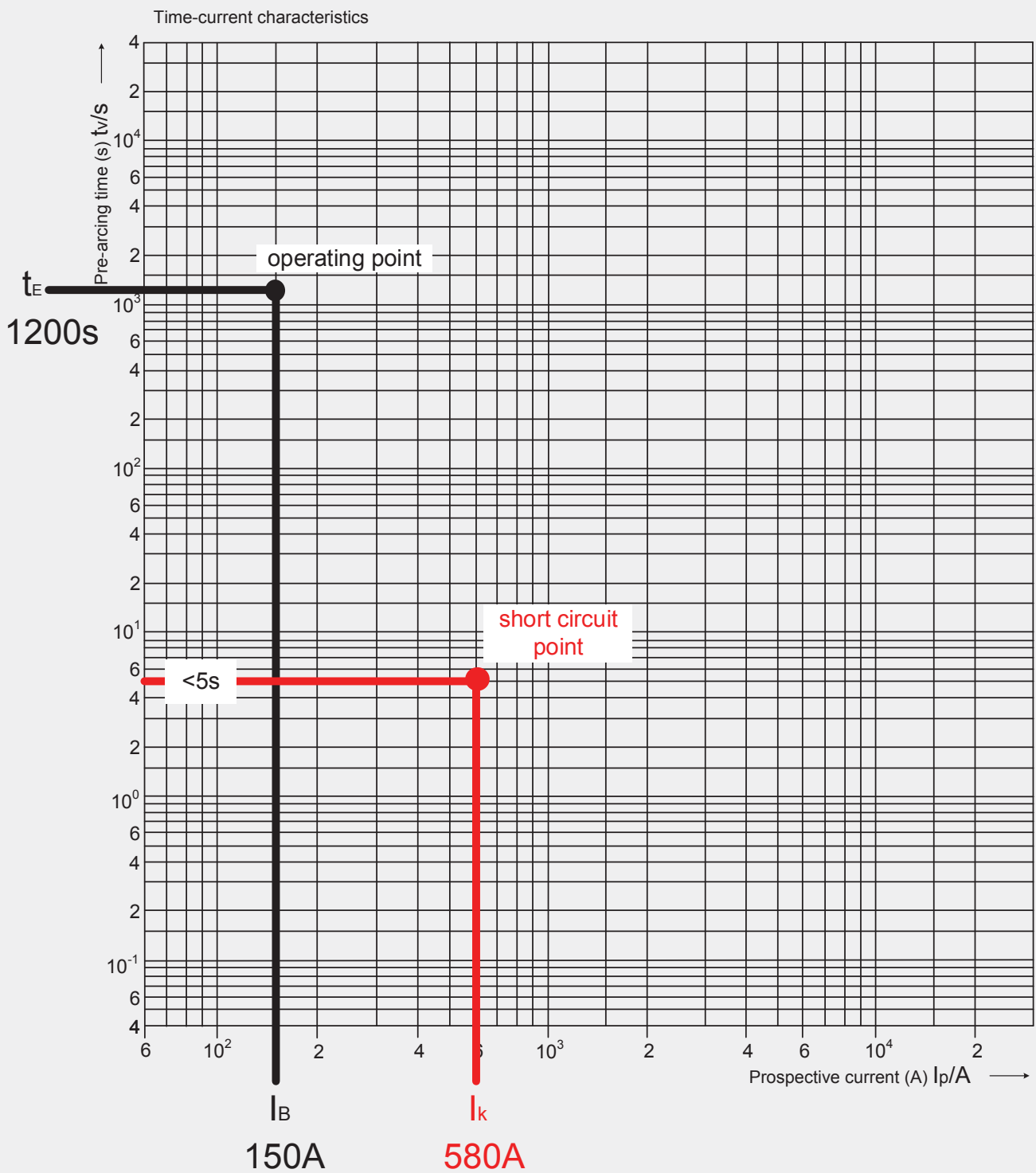

Battery fuse selection-I/t characteristic

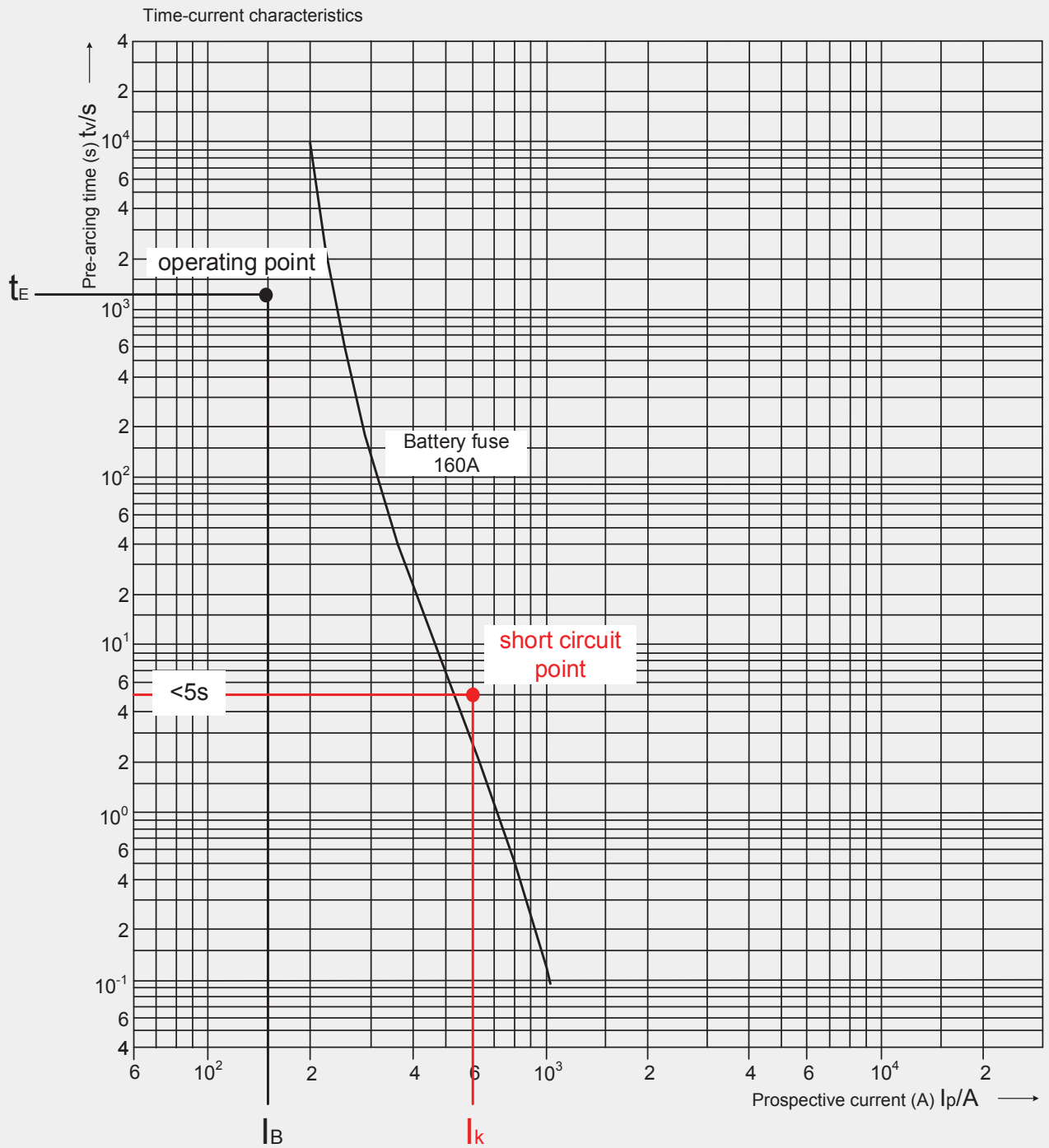

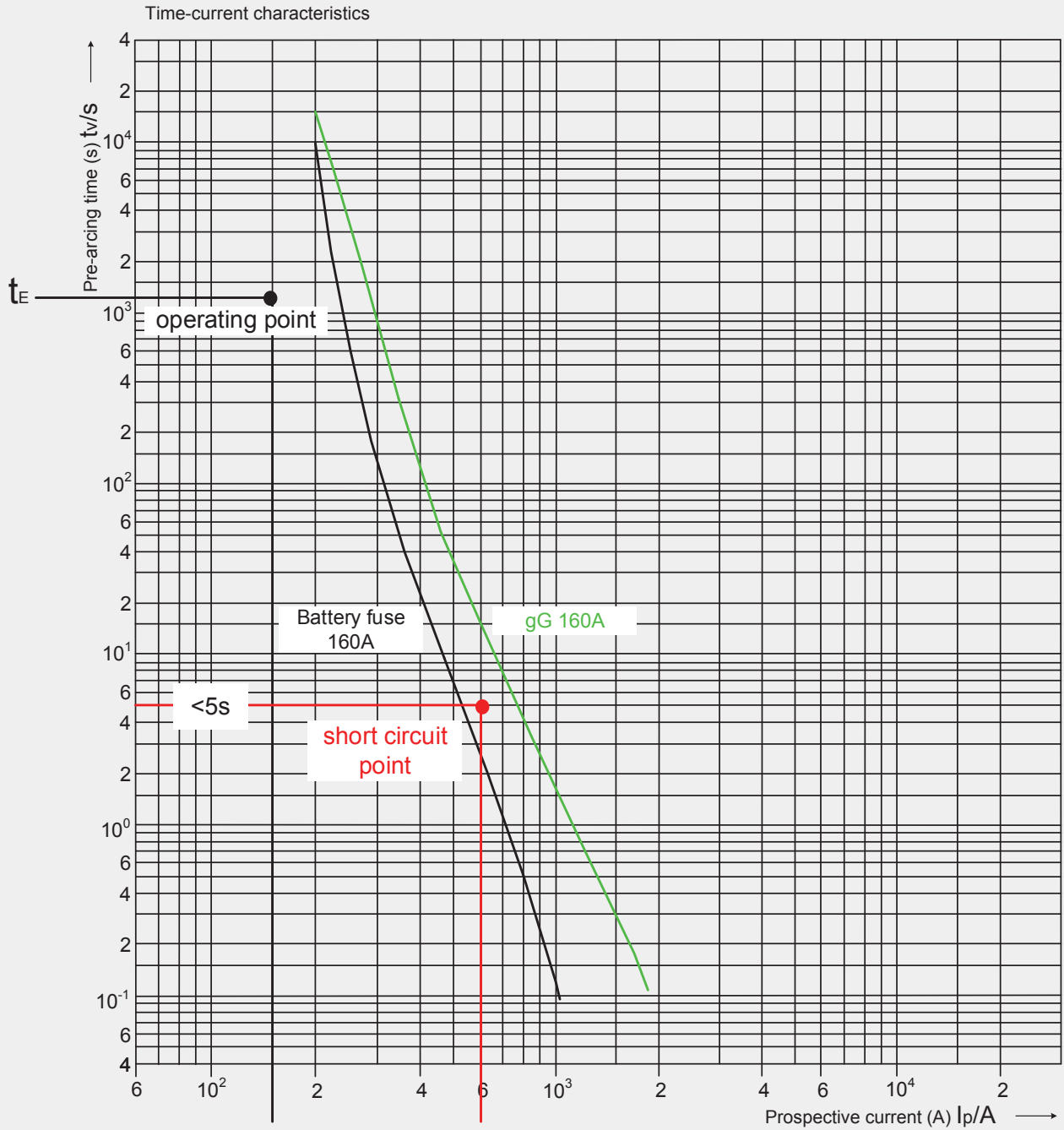

Required operating time

<5s

Battery fuse 700V d.c.
160A
operating time
2,5s

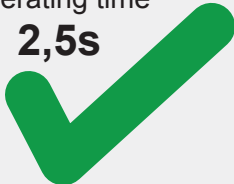

~~gG fuse 160A
operating time
15s~~

~~MCB 160A
operating time
~30s~~

Battery array

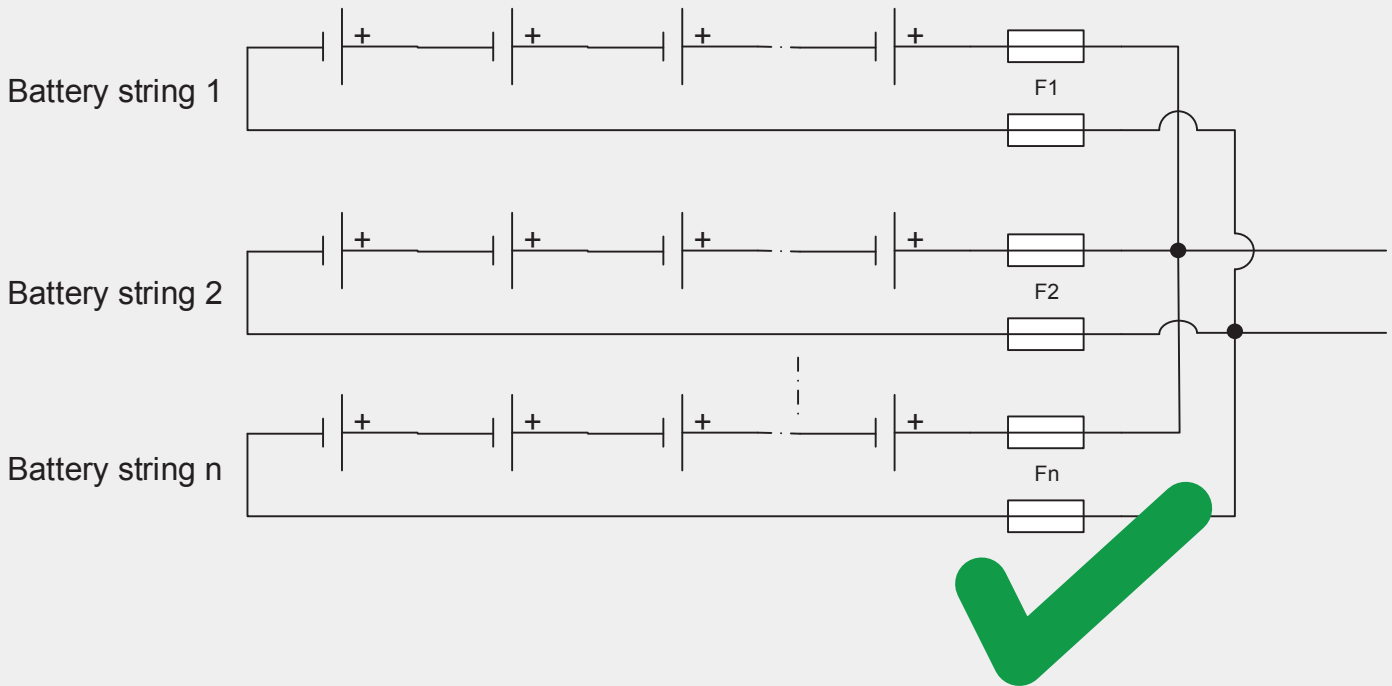

Battery array

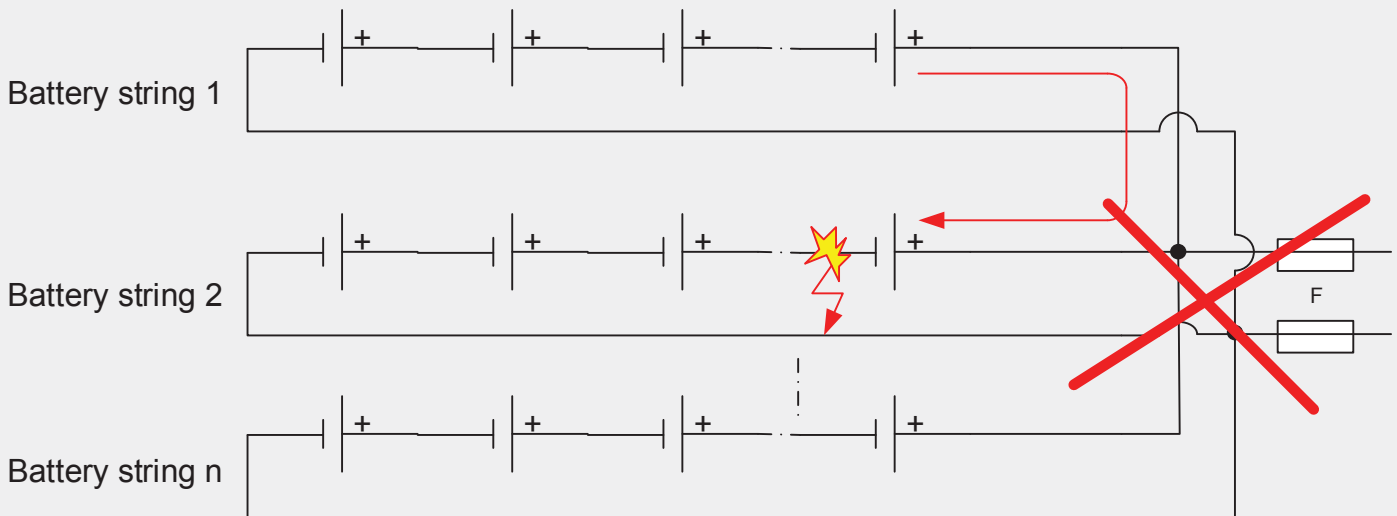

For battery banks with parallel strings, a good practice is to include overcurrent protection for each battery string. This minimizes the potential of the bank backfeeding a single shorted battery, which can lead to fires and property damage.

Battery-string fusing is best accomplished with appropriately sized dc-rated fuses secured in bolt-in fuse holders that are housed in a single enclosure. This arrangement makes it easy to isolate one battery string for testing or maintenance while allowing the system to continue operation. Individual battery-string fuses can provide protection against catastrophic failure in the event of major fault in the main disconnect breaker panel or elsewhere in the battery bank. Series fuses on each battery string also reduce the available shortcircuit current levels, allowing for the use of lower ampere interrupting current rated circuit breakers for the inverter/ charger disconnects. Without the fuses, the amount of current that the circuit breaker has to interrupt during a fault could potentially exceed its rating.

Ratings for Li-ion batteries

Burst discharge (pulse) ratings for Li-ion batteries:

The first set of C ratings on a Li-ion tells us how fast the battery can be discharged.

30C/60C

translates to

(maximum constant discharge rate) / (Burst discharge rate)

Burst can last for <5 seconds. To figure out how many amps this rate is, you need to know the capacity of the battery pack. If the pack says that it has 2,3Ah, take that number before the Ah and multiply with 30 to get the number of amps. In this case, it would be 69A. That is rating of 30C for that pack.

The burst rate would then be $2,3 \times 60 = 138A$ amps for less than 5 seconds.



Specifications: Hypersonic 2300 6.6V

<p>Product Summary: 2S1P cell configuration Li Ion Deans Ultra output/charge connector Balancing connector (Balancing only with Sonic Charge™)</p>	<table border="0"> <tr><td>Voltage:</td><td>6.6V</td></tr> <tr><td>Capacity:</td><td>2300 mAh</td></tr> <tr><td>Max C-rate cont.</td><td>30C</td></tr> <tr><td>Max C-rate pulse</td><td>60C</td></tr> <tr><td>Max Current cont.</td><td>69A (limited by connector)</td></tr> <tr><td>Max Current pulse</td><td>138A</td></tr> <tr><td>Max temperature*</td><td>160F/71°C</td></tr> <tr><td>Size (length x diam)</td><td>135mm x 28mm</td></tr> <tr><td>Weight:</td><td>155g</td></tr> </table>	Voltage:	6.6V	Capacity:	2300 mAh	Max C-rate cont.	30C	Max C-rate pulse	60C	Max Current cont.	69A (limited by connector)	Max Current pulse	138A	Max temperature*	160F/71°C	Size (length x diam)	135mm x 28mm	Weight:	155g
Voltage:	6.6V																		
Capacity:	2300 mAh																		
Max C-rate cont.	30C																		
Max C-rate pulse	60C																		
Max Current cont.	69A (limited by connector)																		
Max Current pulse	138A																		
Max temperature*	160F/71°C																		
Size (length x diam)	135mm x 28mm																		
Weight:	155g																		

Product Specifications

Type:	Lithium Ion
Capacity:	2300 mAh
Voltage:	6.6V
Connector Type:	Deans Ultra (WSD1300)
Number of Cells:	2
Weight:	155g
Configuration:	2S1P
Length:	5.31 in (135mm)
Width:	1.10 in (28.0mm)
Height:	1.10 in (28.0mm)
Maximum Continuous Discharge :	30C
Maximum Burst Discharge :	60C

Examples of maximum discharge current for Lead-acid and Li-ion batteries:

Internal Resistance (Fully Charged Battery).....	<12m Ω
Maximum Discharge Current For 5 sec.(A).....	180A

Storage	-20~60°C
Max. Discharge Current 77°F(25°C)	1000A(5s)
Short Circuit Current	3300A
Charge Method: Constant Voltage Charge 77°F(25°C)	

Capacity	20.0Ah@20mA rate
Weight	Approx. 5.9 Kg
Max. Discharge Current	200 A (5 sec)
Internal Resistance	Approx. 12 mΩ
Operating Temperature Range	Discharge: -20°C ~ +

Continuous discharge current	100 A	100 A
Max discharge impulse current: (10 min.)	200 A (temperature controlled)	200 A (temperature controlled)
(5 sec.)	>500 A	>500 A
(µSec.)	>1000 A	>1000 A
Continuous charge current	100 A	100 A

Max. Discharging Rate	<ul style="list-style-type: none"> 66A (30.0C), Maximum continuous discharge, Recommended 132A (60.0C), Maximum Burst rate < 5 seconds
Dimensions (LxWxH)	116mm(4.6") x 38mm(1.5") x 40mm(1.6")
Weight	10.8 Oz (300 g)

A few reasons why protection of batteries with simple fuse link is not OK:

- ✓ Flammable hydrogen gas is always present during battery recharging. Hydrogen gas is potentially explosive if allowed to accumulate in a closed area.
- ✓ Prevent open flames, sparks, or **electrical arcs** in the battery charging area to minimize the danger of explosion.
- ✓ Breaking capacity of »fork lift fuse link« is less than 1kA at nominal voltage!



Comparison characteristics

Battery fuse ← → Semiconductor protection fuse

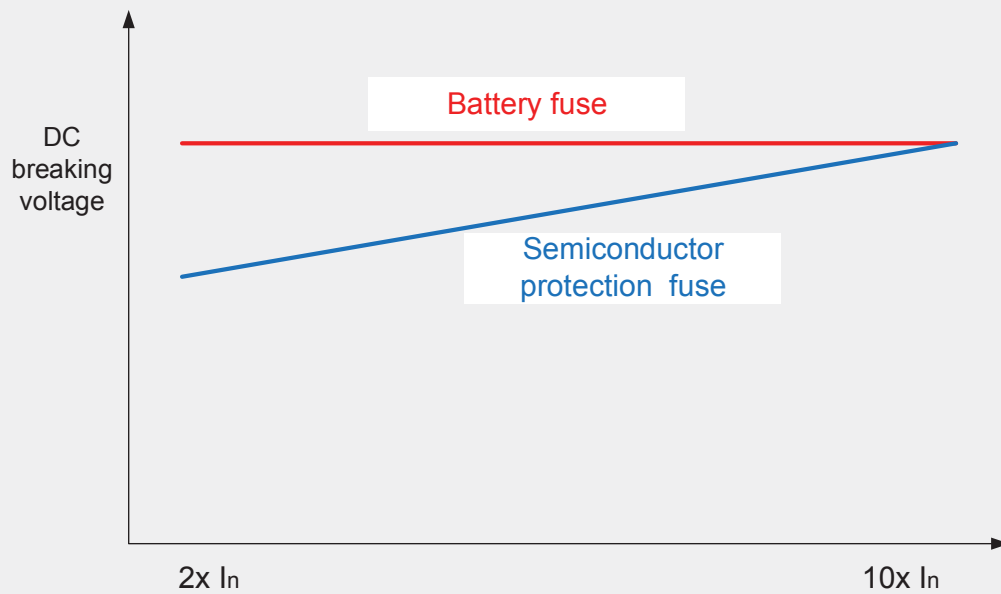
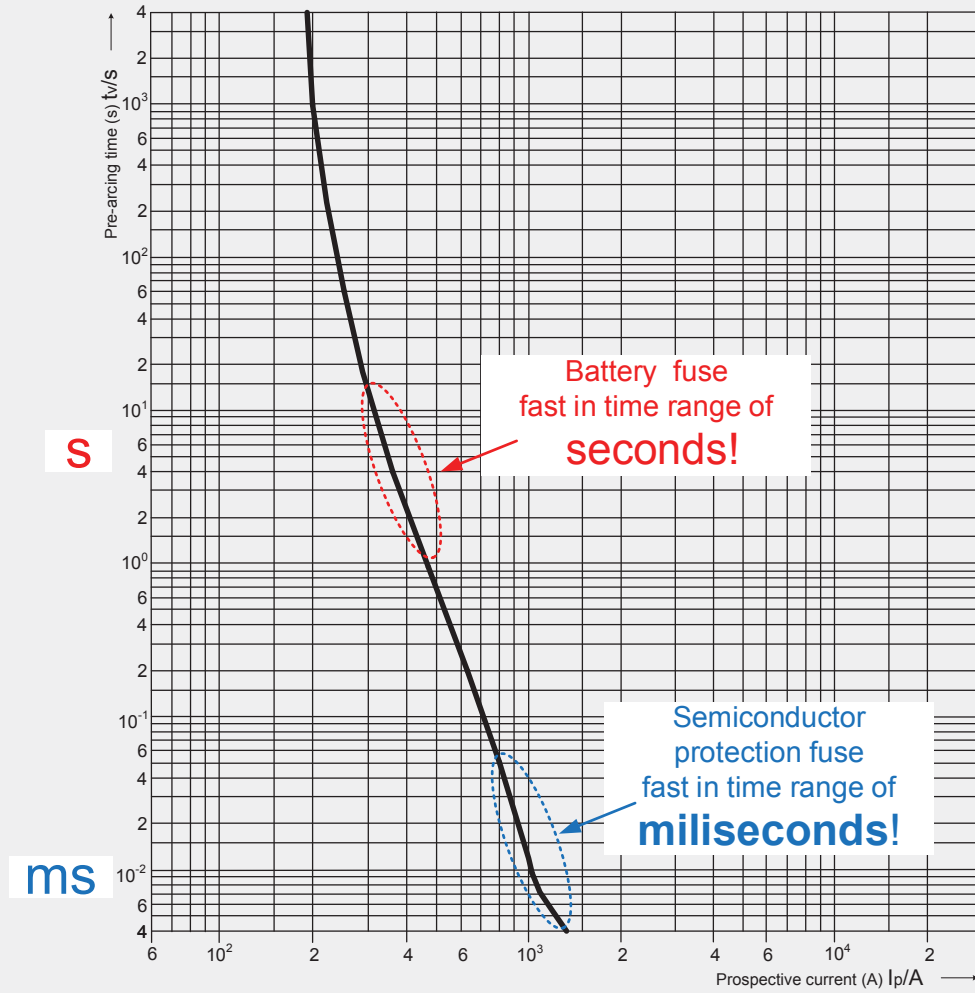



www.etigroup.eu

May 2016

ETI d.d. withholds the right to make changes and additions to any information contained herein.